

# Operator's Manual & Parts List

## TDR-X

Serial No. 20111003 and up



PROGRESSIVE TURF EQUIPMENT INC.  
137 WEST WILLIAM STREET  
SEAFORTH, ONTARIO  
CANADA N0K 1W0  
TOLL FREE: 800 668-8873  
[www.progressiveturfequip.com](http://www.progressiveturfequip.com)  
ISSUE DATE: January 2021  
P.N. 120596

**PROGRESSIVE**  
TURF EQUIPMENT INC.

*The Better Built Choice.™*



<b>TABLE OF CONTENTS</b>	<b>PAGE</b>
<b>INTRODUCTION</b> .....	<b>3</b>
<b>FOREWORD</b> .....	<b>3</b>
ITEMS INCLUDED WITH TDR-X MOWER.....	4
SERIAL NUMBER LOCATION.....	4
REPLACEMENT PARTS INFORMATION .....	4
UNAUTHORIZED MODIFICATION.....	5
MISUSE OF EQUIPMENT .....	5
NOTIFICATION OF UNAUTHORIZED MODIFICATION OR MISUSE .....	5
PRODUCT DESIGN .....	5
<b>SPECIFICATIONS</b> .....	<b>6</b>
<b>COMPONENT IDENTIFICATION</b> .....	<b>7</b>
<b>SAFETY RULES</b> .....	<b>8</b>
SAFETY ALERT SYMBOL.....	8
HAZARD SERIOUSNESS LEVEL .....	8
GENERAL SAFETY PRECAUTIONS .....	9
POWER UNIT SAFETY.....	9
OPERATING EQUIPMENT SAFELY .....	10
MAINTENANCE SAFETY PRECAUTIONS .....	11
WELDING / GRINDING WORK PRECAUTIONS .....	12
HYDRAULIC SYSTEM SERVICE PRECAUTIONS.....	13
SAFETY DECALS .....	14
DECAL LISTING.....	15
<b>ASSEMBLY INSTRUCTIONS</b> .....	<b>16</b>
INSTALLING DECK PTO SHAFTS:.....	17
<b>MOWER SETUP FOR OPERATION</b> .....	<b>19</b>
DRAWBAR ADJUSTMENT .....	19
HITCHING THE MOWER TO THE TRACTOR .....	20
STOWING THE JACK.....	20
CONNECTING THE PTO TO THE TRACTOR.....	20
CONNECTING THE HYDRAULICS.....	21
CONNECTING THE PULL ROPE .....	21
MOWER SAFETY LOCKS .....	21
DECK LOCK SYSTEM .....	21
TRANSPORT LOCK.....	22
CHECK PTO LENGTH - TURNING AND ON HILLS .....	23
CV JOINT INPUT SHAFT.....	24
DISCONNECTING THE MOWER.....	24
<b>ADJUSTING THE MOWER FOR CUTTING</b> .....	<b>26</b>
SETTING HEIGHT OF CUT .....	26
<b>OPERATING THE MOWER</b> .....	<b>27</b>
DAILY CHECK LIST .....	27
RAISING / LOWERING THE WINGS & DECKS.....	27
ENGAGING THE PTO.....	28
MOWING .....	28
Pro Lift-N-Turn™ SYSTEM.....	29
<b>TRANSPORTING THE MOWER</b> .....	<b>30</b>
TIE DOWN LOCATIONS.....	30
<b>MAINTENANCE</b> .....	<b>31</b>
LUBRICATION .....	32

CHECK OPERATION OF LOCK SYSTEM .....	34
“V” BELT DRIVE .....	36
FASTENER INSTALLATION TORQUE .....	37
BLADE SERVICING .....	38
SPINDLE SERVICE .....	41
HYDRAULICS .....	43
SUPPORTING MACHINE FOR SERVICE.....	44
TRANSPORT TIRES.....	44
LONG-TERM STORAGE .....	44
TROUBLE SHOOTING .....	45



**DANGER!**

Si usted No Lee Ingles, Pida Ayuda a Alguien Que Se Lo Lea  
Para Que le Traduzca Las Medidas de Seguridad



## INTRODUCTION

Thank you for purchasing a TDR-X mower. This product is designed and manufactured to allow safe and productive mowing of contoured areas. A well-maintained machine will provide years of reliable service.

## FOREWORD

Keep this manual with the mower at all times. This manual is intended as a guide to the safe use and maintenance of the machine, so before you operate this machine, study this manual carefully.

**Replace this manual immediately if it becomes lost.**

This manual is not considered all-inclusive, so for further information on specific components, e.g. PTO shafts etc refer to the respective documents included with the manual set for this machine.

The TDR-X mower is a contour roller turf grass finishing mower with a 10.5 foot cutting width, and is designed to be pulled by a 35-40 PTO horsepower utility tractor. These versatile mowers have the ability to mow both contoured and flat terrain that requires a high quality, finished after cut appearance. High blade tip speed leaves a second-to-none after cut appearance. 6-way floating decks, and an Adaptive Swivel Hitch isolates the tractor from the mower allowing truer contour tracking.

Features:

- Three independent floating decks
- Cut height can be set on each deck between 3/8 inch and 3 3/8 inches
- 10.5 foot cutting width
- Adaptive Swivel Hitch
- Pro Lift-N-Turn™ allows three decks to be temporarily raised slightly off the ground with the PTO still engaged
- Automatic mechanical deck locks for transport

Applications:

- Golf course roughs, fairways and bunker surrounds
- Corporate and industrial campuses
- Park lands and recreational areas & sports venues
- Landscaped venues

<b>TDR Series Mower Application Guide</b>	
<b>Model</b>	TDR-X
<b>Soil Type</b>	All (firm ↔ sandy)
<b>Turf Condition</b>	All conditions
<b>Comments</b>	For use in areas where ride-on reel-type mowers cannot be used.

**OSHA Training Requirements (USA)**

The following training requirements have been taken from Title 29, Code of Federal Regulations Part 1928.57 (a)(6). [www.osha.gov](http://www.osha.gov)

Operator Instructions: At the time of initial assignment and at least annually thereafter, the employer shall instruct every employee in the safe operation and servicing of all covered equipment with which he is or will be involved, including at least the following safe operating practices.

In other jurisdictions:

It is good practice, following the initial instruction and at least annually thereafter, that the employer instruct every employee in the safe operation and servicing of all covered equipment with which he is or will be involved, including at least the following safe operating practices.

## ITEMS INCLUDED WITH TDR-X MOWER

TDR-X Operator's Manual & Parts List

Service instructions for PTO drive shafts

Blade balancer tool – \*One piece blades only, not used for swing blades

## SERIAL NUMBER LOCATION

The serial number plate for the machine is located on the left-hand front frame.

For quick reference, record the following information:

Model: \_\_\_\_\_ TDR-X \_\_\_\_\_

Serial Number: \_\_\_\_\_

Date purchased: \_\_\_\_\_

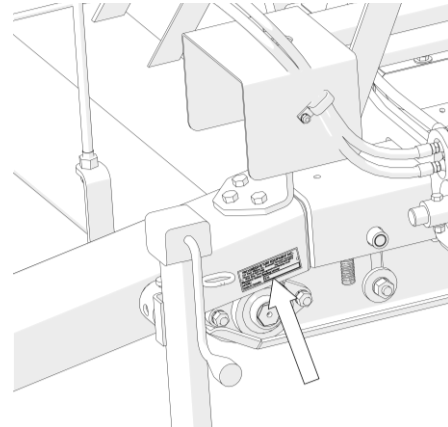

NOTE: The last digit in each TDR-X serial number is a letter. This letter denotes the geographic destination of the mower.

D EU Regulatory Region

B Non- EU Regulatory Region



There are differences in the parts required to service your mower based on this geographic code as are referred to throughout the parts lists. Always state this information when contacting your selling dealer and when ordering spare parts.

## REPLACEMENT PARTS INFORMATION

Use only Genuine Original Equipment Manufacturers (O.E.M.) replacement parts. The use of "will fit" parts may reduce machine performance, void machine warranty and present a safety hazard. Use only Genuine OEM replacement parts.



Under our policy of continuous improvement, we reserve the right to change specifications and designs without prior notice. The illustrations shown do not necessarily represent the standard version of product offered by Progressive Turf Equipment Inc.

## **UNAUTHORIZED MODIFICATION**

Modifications to the original design of the TDR-X mower, including the use of unauthorized accessories or non-genuine OEM parts, may affect the reliability of the machine or make it unstable or unsafe to operate and perform as originally designed and intended. Persons or organizations that make unapproved modifications (including operation without provided guards and shields) assume all liability arising from or related to the modification including any adverse affect on the machine.

No modification can be made to the original design or assembly of the TDR-X mower (including any and all attachments, safety or control devices) without the prior written consent of the Progressive Turf Equipment Inc.'s Engineering Manager (see contact information below). Progressive Turf Equipment Inc. retains the right to reject all claims which arise from or are related to unauthorized modifications.

Modifications are officially approved if at least one of the following conditions is met:

- i. The attachment, accessory or part is distributed by Progressive Turf Equipment Inc. and is intended for a TDR-X mower application and installed in an approved manner as described in Progressive Turf Equipment Inc.'s provided instructions; or
- ii. The modification has been approved in writing by the Progressive Turf Equipment Inc.'s Engineering Manager.

No other entity is authorized by Progressive Turf Equipment Inc. to provide such approval.

## **MISUSE OF EQUIPMENT**

It is incumbent upon the user, owner and selling dealer of this equipment along with their respective employees to warn and discourage users about the misuse of the equipment whenever knowledge of misuse becomes known, whether the act has, is or could occur. Such acts include, but not limited to: riding upon, use of non-OEM parts, operation on unstable or dangerous terrain, operating in explosive or fire-hazard areas, modifications that alter the original machine specifications or use other than originally intended, etc.

## **NOTIFICATION OF UNAUTHORIZED MODIFICATION OR MISUSE**

If any person, employee, agent, dealer or distributor becomes aware of any Unauthorized Modification or Misuse of a TDR-X mower, either past or intended, it is the responsibility of that person to ensure that Progressive Turf Equipment Inc.'s Engineering Manager is notified of the occurrence promptly. That person shall provide; the facts of the occurrence, location, machine serial number, name and contact information of the persons involved.

Send correspondence regarding Unauthorized Modification or Misuse to:

Progressive Turf Equipment Inc.  
Box 940, 137 West William St.  
Seaforth, Ontario, N0K 1W0  
Canada  
Attn: Engineering Manager

## **PRODUCT DESIGN**

The TDR-X mower has been designed and produced using generally acceptable manufacturing processes as is standard in the industry for the type of equipment that is similar to the machine. As such, the useful life of the machine is ten (10) years from the date of manufacture.

### **The official language of the manufacturer is English.**

No responsibility is assumed for translations in other languages, which do not correspond to the original meaning.

## SPECIFICATIONS

### Tractor Requirement

PTO Horsepower.....	35-40 hp
PTO Input Speed.....	540 rpm
Maximum Hydraulic Pressure .....	3000 psi
Maximum Implement Hydraulic Flow .....	17 US gpm

### Machine Specifications

Cutting Width	..... 10.5 ft.
Turning Radius	Zero-Turn Capability.
Cutting Height	Minimum.....3/8 in. Maximum.....3 3/8 in
Flexibility	
Mower Decks	Fore & Aft Rotation..... +/- 10° Left & Right Rotation ..... +/- 10° Vertical Movement ..... +/-8 in
Hitch	Rotation .....6-way movement
Mower Decks	
Configuration	3 deck independent staggered
Floatation	6-way
Construction	Welded Steel – 3/16 in. (7 ga) thickness
Spindles	30mm spindles are each carried in 2 maintenance free ball bearings, which are housed, in a precision machined hub
Blades	High lift, heat treated, alloy steel blades 5/16" x 2 1/2" x 16 3/4" (3) per deck or Pro EZII replaceable blade tips
Blade Mounting	Two bolts/nuts per blade (No internal threads)
Rollers	Full width, heavy wall reinforced ends, with HEX drive, supported by (2) 1.25 hex bearings in ductile iron housing.
Power Transmission	
Input Shaft	1 3/8 dia – 6 Spline 80° Constant Velocity /w auto locking collar
Gearbox	Cast Iron Housing /w Helical gears
Deck Drive	Fiber reinforced V-Belts, 2 per deck
Belt Tensioning	Positive Draw bolt tensioner (1 per deck)
Transport Tires	(2) Heavy Duty 23 X 9.5-12, 5 bolt.
Productivity*	4 mph .....5.0 acres / hr. 6 mph .....7.6 acres / hr. *Assumes no overlap or turning
Transport Dimensions	Width .....6ft. 6in. (Max) Height.....6 ft Length ..... 11ft 6in.
Weight	Machine.....3250 lbs

Under our policy of continuous improvement, we reserve the right to change specifications and designs without prior notice. The illustrations shown do not necessarily represent the standard version of product offered by Progressive Turf Equipment Inc.

## COMPONENT IDENTIFICATION

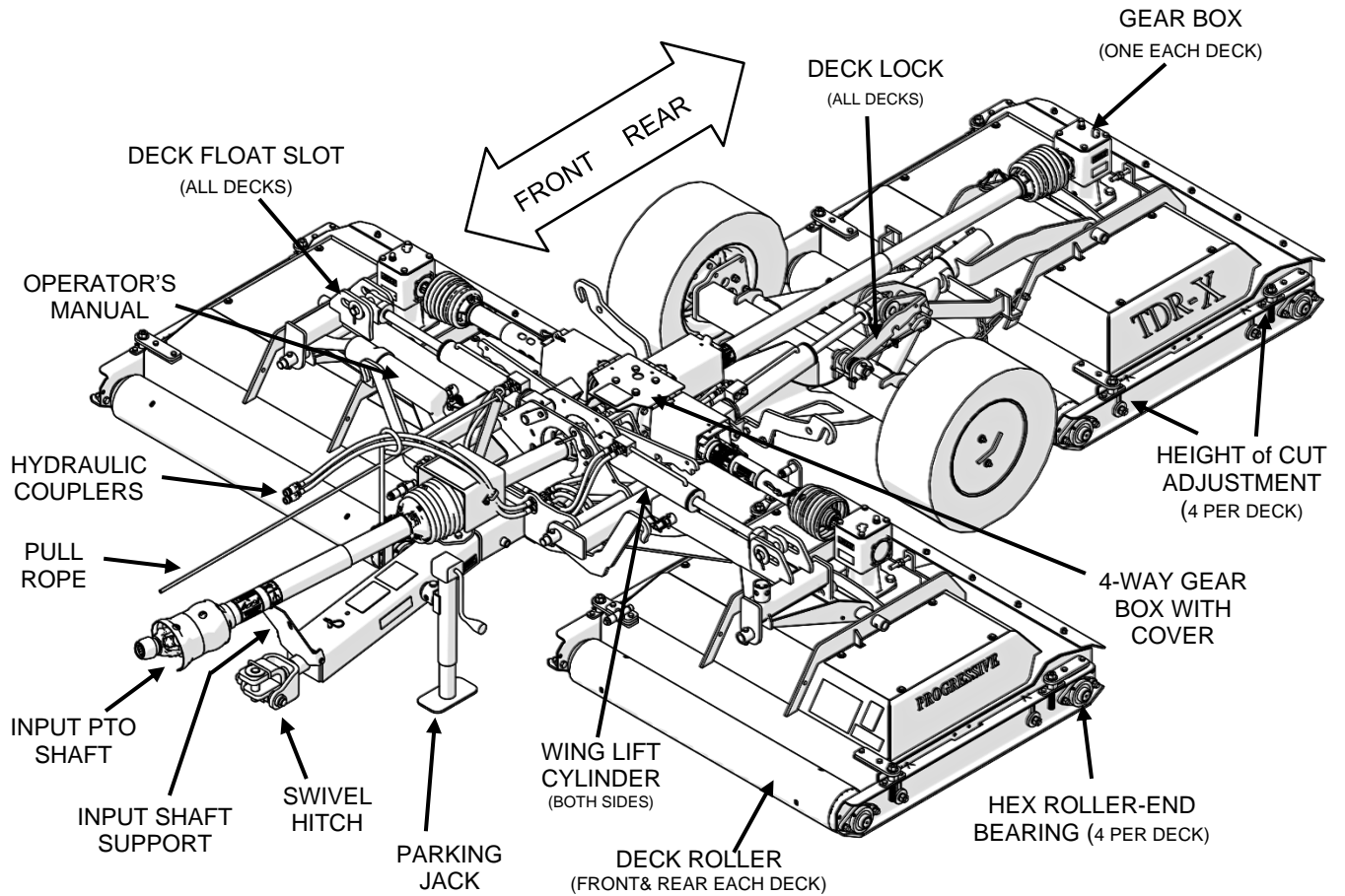

### NOTES

- 1) Throughout this manual, references are made to right and left directions. These are determined by standing at the rear of the equipment and facing the direction of forward travel.
- 2) Blade rotation is identical on all three decks, all locations. The blades are expressed as "Left Hand" (LH) and rotate counter-clockwise as viewed from the top of the mower.

## SAFETY RULES

All rotary mowers are potentially dangerous machines; this mower has been designed to minimize the safety risks to the operator, bystanders and property. This section of the Operator's Manual details a number of safety rules pertaining to the operation and maintenance of Progressive Turf Equipment mowers. In order to minimize risks and promote safety at all times, these rules must always be followed and obeyed.

Further safety rules and warning texts are given within the respective sections of this manual.

**IMPORTANT! - When it comes to safety, nothing will ever replace a careful operator.**

It is imperative that the operator and safety personnel read and understand the safety information in this manual before proceeding. Failure to follow the instructions or heed the warnings could result in injury or death.

Proper care is your responsibility.

The manufacturer cannot anticipate every possible circumstance that might involve a hazard. The hazard alerts in this publication and on the product, are therefore not all inclusive. If a tool, procedure, work method, or operating technique not specifically recommended by the manufacturer is used, it is your responsibility to ensure that it is safe for you and others. You should also ensure the machine will not be damaged or made unsafe by the operation, maintenance, or repair procedures you choose. Modifications or adaptations to the machine are not allowed.

Various jurisdictions have specific requirements for work zone safety. Know and adhere to your local requirements. Treat the instructions in this manual as minimum requirements for safe operation.

## SAFETY ALERT SYMBOL

This symbol appears at various points in the manual together with a signal word and warning text. It means – Be alert! Your safety is involved. This symbol is used throughout the manual to call attention to areas in which carelessness or failure to follow specific procedures may result in personal injury or component damage / malfunction or both.

## HAZARD SERIOUSNESS LEVEL

The following signal words are found throughout the manual together with the safety alert symbol to indicate the seriousness level of identified hazards. Their selection is based on the consequence of human interaction with a hazard.

**DANGER!** – Hazards or unsafe practices which WILL result in severe personal injury or death.

**WARNING!** – Hazards or unsafe practices that COULD result in severe personal injury or death.

**CAUTION!** – Hazards or unsafe practices that COULD result in minor personal injury or product or property damage





## GENERAL SAFETY PRECAUTIONS

### WARNING!

- The operator of this machine must have sufficient knowledge and instructions in the care and operation of this mower and the power unit being used before he / she uses the machine. Do not allow unauthorized persons or children to operate the machine. Do not allow riders on the machine.
- It is the obligation of the operator to make sure that all guards and shields are in place on the machine. Safety decals must be in place and be readable – accidents may otherwise occur. Contact your dealer or the manufacturer for replacement manuals or decals.
- Never use a machine that does not have an operator's manual available. Learn and understand the safety signs and symbols on the machine and the operator instructions before you begin to use the machine.
- Wear personal protective equipment. Know and use the protective equipment that is to be worn when operating or servicing the machine. Hard hats, protective glasses and face shields, protective shoes, gloves, reflector type vests, and ear protection are types of equipment that may be required. Prolonged exposure to loud noise can cause hearing damage.
- Never operate a mower while under the influence of drugs or alcohol. These make reflexes slow and put you and others in grave danger. Always make sure you have full concentration while mowing.
- Adhere strictly to all regulations at the worksite pertaining to the operation of this equipment.
- Always disengage power takeoff (PTO) when transporting or traveling between work sites.
- Be prepared for emergencies. Have a first aid kit, fire extinguisher and emergency contact information available at the work site.

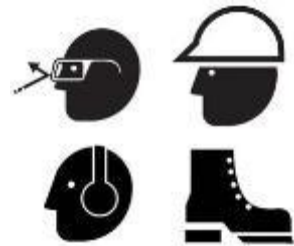

## POWER UNIT SAFETY

### WARNING!

- The operator must have sufficient knowledge in the care and operation of the power unit (tractor) before connecting power unit to mower. Read and understand power unit operator's manual before connecting mower.
- Power unit must be equipped with ROPS and seat belt. Foldable ROPS must be secured in the upright position. Follow recommendations of power unit manufacturer. Seat belt must be worn at all times.
- Power unit must be equipped with a 1-3/8" 6 spline 540 RPM PTO connection. Never use PTO adapters to connect implements. Never connect mower driveline to 1000 RPM PTO.

## OPERATING EQUIPMENT SAFELY

### WARNING!

- Never allow persons to stand between power unit and mower while backing power unit up to hitch the mower.
- Before hitching mower to power unit, place transmission in neutral, set park brake, and turn engine off. Remove the ignition key.
- Make sure locking collar on PTO shaft is properly locked. If the PTO shaft comes off during operation, personal injury or equipment damage could result.
- Tall grass can hide obstacles. Carefully walk the entire area to be mowed beforehand. Look for debris, rocks, tree limbs etc. that will damage or be thrown by the mower blades. Identify objects that cannot be removed. Set mower cutting height to avoid contact.
- Ensure that no bystanders are within 10 ft of mower when wing transport locks are released.
- Keep all bystanders well away from the machine when it is operating. Always maintain a safe operating distance from personnel, other equipment, or vehicles.
- Never operate the mower with deflectors or guards removed. Mower blades can cause small objects and debris to be thrown from under the mower deck at high speeds, up to 300 ft away. Objects ejected by the mower blades can cause severe injury.
- Never tamper with safety devices or operate the mower with them removed. Check proper operation regularly.
- Always disengage PTO, place all controls in neutral, turn power unit off, set parking brake, and remove key before dismounting, for any reason.
- Never place hands or feet under mower deck when the mower is operating, or power unit engine is running.
- Disengage the PTO when crossing gravel areas or roadways.
- Disengage the PTO and turn power unit off upon striking any object. Inspect mower and repair any damage before continuing.
- If the equipment should start to vibrate abnormally during operation, stop the mower, shut down power unit, and immediately check for the cause. Excess vibration is generally an indication of a problem. Replace bent or damaged parts, do not attempt to straighten a bent blade.
- Use extreme care when operating on uneven terrain.
- Reduce speed when operating on slopes during wet conditions, especially when making sharp turns.
- Do not use the mower in limited visibility (e.g. at dusk, in fog, heavy rain etc.). Mow only in daylight or good artificial light.
- Disengage PTO and ensure blades are completely stopped before raising wings.
- Ensure wing and deck safety locks are securely engaged before transporting mower with wings in raised position.
- **Mower is not intended for transport on public roadways.**



- Before disconnecting from power unit, always lower equipment to the ground, place controls in neutral, set park brake, turn engine off, and wait for all moving parts to stop. Relieve hydraulic pressure per power unit manufacturer's instructions.
- Ensure mower tongue jack is securely fastened to mower frame with supplied pin before removing hitch draw pin.

## MAINTENANCE SAFETY PRECAUTIONS

### WARNING!

- Never make adjustments or repairs with the engine running. Always disengage PTO, engage parking brake, turn engine off, lower wings to cutting position and relieve hydraulic pressure before performing any maintenance.
- Observe and perform proper lock-out procedures for power unit if attached to mower during service.
- Keep nuts and bolts tight and properly at the proper torque, especially blade attachment bolts. Check that all cotter pins are properly installed. Keep equipment in good condition.
- Keep mower free of grass, leaves, or other debris build-up.
- Never work on raised mower decks without safety locks in place.
- Periodically check condition of safety devices, guards, and deflectors. Replace only with manufacturer's recommended parts.
- Inspect and replace damaged blades. Use only original OEM parts. Blades can fail from poor maintenance practices.
- Handle mower blades carefully. They are sharp and can cut unprotected skin. Use caution and wear gloves when handling them.
- Check to make sure hydraulic hoses are not worn or damaged and are routed to avoid chafing.
- Immediately replace any hydraulic hose that shows signs of swelling, wear, leaks, or damage so it does not burst.
- Do not use your hand to check for hydraulic oil leaks. Use a piece of cardboard instead. Hydraulic fluid escaping under pressure can penetrate the skin causing serious injury. If skin penetration occurs, seek medical attention immediately. Relieve all pressure before disconnecting hoses.
- Do not bend or strike hydraulic lines, tubes, or hoses, or reinstall them in a bent or damaged condition.
- Inspect tires daily for wear or damage. Check tire pressures weekly with an accurate pressure gauge. Do not inflate tires beyond 20 psi.
- Mounting and dismounting tires from rims can be dangerous and should be performed by trained personnel using correct tools, equipment, and procedures.



- Do not support the machine on cinder blocks, hollow tiles or other members that may fail under continuous load.
- Never perform service on a machine that is supported solely by a jack. Always ensure proper blocking is placed to support load during service.



## WELDING / GRINDING WORK PRECAUTIONS

**IMPORTANT! A fire extinguisher should be easily accessible during all welding work.**

Welding repairs are to be performed by a trained welder with proper service instructions. Know the material to be welded and select the correct welding procedure and materials (electrodes, rods, wire) that will provide a weld metal strength equivalent to the parent material.

Move the machine to a clean, safe area before welding, grinding or using a cutting torch on it. This type of work should only be done in a clean area and not in places that contain combustible liquids, such as fuel tanks, hydraulic pipes or similar.

Connect arc welder ground as close as possible to work area.

Work with extra care when welding, grinding or torch cutting near flammable objects.

### WORKING ON PAINTED SURFACES

Heated paint gives off poisonous gases. Therefore, paint must be removed from an area with a radius of at least 4 in (10 cm) before carrying out welding, grinding, or gas cutting. In addition to the health hazard, the weld will be of inferior quality and strength if the paint is not removed.

Methods and precautionary measures when removing paint:

Blasting – use respiratory protective equipment and protective goggles.

Paint remover or other chemicals – use a portable air extractor, respiratory protective equipment, and protective gloves.

Grinding – use a portable air extractor, respiratory protective equipment, and protective gloves and goggles.



### WORKING ON GALVANIZED / PLATED SURFACES

Only qualified welders should attempt a weld repair on galvanized or plated components. Proper pre-welding surface preparation is required.

Always ensure proper ventilation, wear proper respiratory protective equipment and avoid direct contact with smoke emitted from the welding process.

## HYDRAULIC SYSTEM SERVICE PRECAUTIONS

### WARNING!

**Risk of personal injury! Wear safety glasses and use protective gloves.**

Relieve all trapped pressure before performing any service to the hydraulic system. Pressure can be maintained in the hydraulic circuits long after the power source and pump have been shut down.

When servicing any hydraulic component of the mower ensure that all decks and wings are in their lowered position and all hydraulic pressure is relieved.

Tighten all connections before applying pressure.

It is important that each person who comes in contact with the machine be alert to any faults.

Follow these basic precautions:

- Never adjust a pressure relief valve or other pressure-limiting device to a higher pressure than specified.
- Check to make sure hydraulic hoses are not worn or damaged and are routed to avoid chafing.
- When connecting mower to tractor ensure hydraulic hoses have sufficient slack for negotiating turns and uneven terrain.
- Immediately replace any hydraulic hose that shows signs of swelling, wear, leaks or damage so it does not burst.
- Do not use your hand to check for hydraulic oil leaks. Use a piece of cardboard instead. Hydraulic fluid escaping under pressure can penetrate the skin causing serious injury. If skin penetration occurs, seek medical attention immediately. Relieve all pressure before disconnecting hoses.
- Do not bend or strike high-pressure lines, tubes, or hoses, or reinstall them in a bent or damaged condition.

### HYDRAULIC OIL HANDLING PRECAUTIONS

Oils can irritate and damage the eyes, throat, and sensitive skin. Avoid contact.

Petroleum based oils are hazardous to the environment. Take special care not to spill or discharge these fluids. Use approved containers and methods to handle and dispose of them.

Use an authorized disposal and recycling company.



## SAFETY DECALS



If decals become faded, damaged, or lost, replace immediately. Order Decal Kit, Part # 541503.

ITEM NO.	DESCRIPTION	QTY
1	DANGER – READ MANUAL	1
2	WARNING-BLADE HARDWARE	1
3	CAUTION – REPLACE SHIELDS	8
4	COMPANY NAME	1
5	DANGER - BLADE HAZARD	7
6	WARNING – OEM PARTS	1
7	CAUTION –DISENGAGE PTO	1
8	PTO GREASING	
9	NOTICE – HITCH SETUP	1
10	MOWER MODEL	2

ITEM NO.	DESCRIPTION	QTY
11	PROGRESSIVE	2
12	PTO – READ MANUAL	1
13	SAFETY SIGN - OUTER GUARD	4
14	PTO ALIGNMENT	1

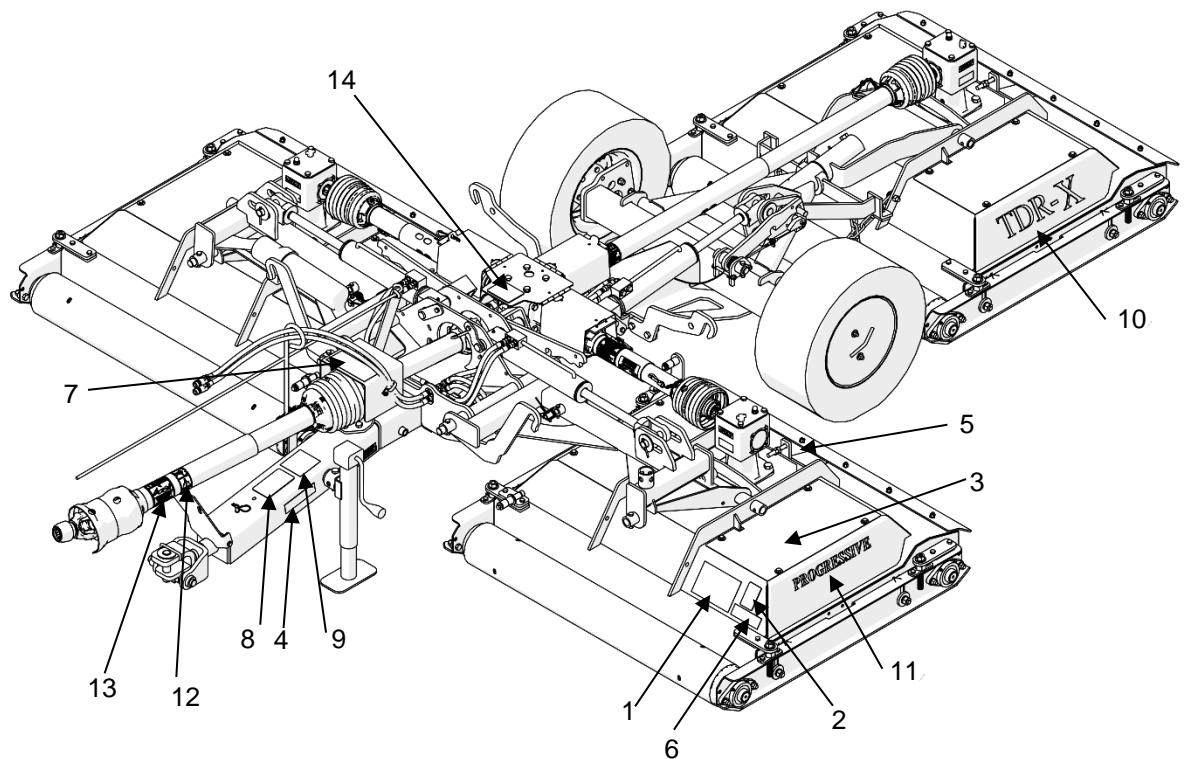



# DECAL LISTING

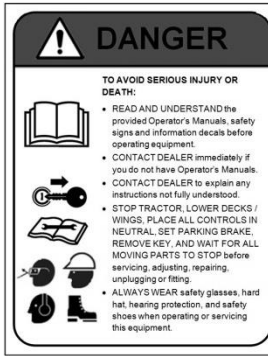

No. 1 - 209172



No. 2 - 209196



No. 3 - 209113



No. 4 - 521817



No. 5 - 209173



No. 6 - 209115



No. 7 - 209174

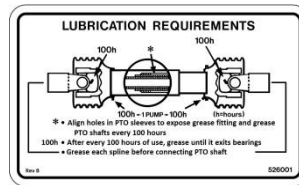

No. 8 - 526001



No. 9 - 521784

# TDR-X

No. 10 - 209203

# PROGRESSIVE

No. 11 - 209103

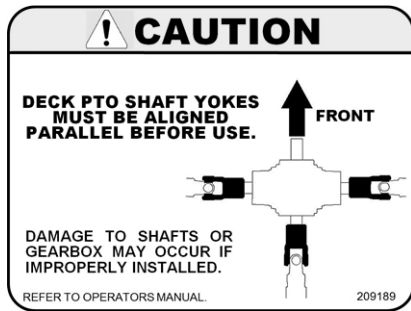

No. 14 - 209189



No. 15 - 521014



No. 12 - 210238



No. 13 - 210237

## ASSEMBLY INSTRUCTIONS

### CAUTION!

Mower assembly must be completed by a qualified technician using safe work practices and proper tools.

**INPUT SHAFT** – shipped strapped to wing deck swivel

1. Remove ½" UNC retaining bolt/nut from input shaft.
2. Remove notification tag from intermediate shaft hanger bearing.

### CAUTION!

**IMPORTANT** - Ensure gold colour spacer ring is present against bearing inner race.

3. Disconnect input shaft shield at clamp yoke end and slide shield exposing the clamp yoke (see input shaft service instructions in mower manual storage tube).
4. Place the Input shaft on the provided support.
5. Install input shaft clamp yoke on intermediate shaft, ensuring gold coloured spacer ring is in place between the input shaft yoke and hanger bearing race.
6. Reinstall ½" UNF retaining bolt in input shaft yoke, torque to 85 ft-lb.
7. Reinstall input shaft shield per input shaft service instructions.
8. Fasten input shaft guard retaining chain to mower main frame.

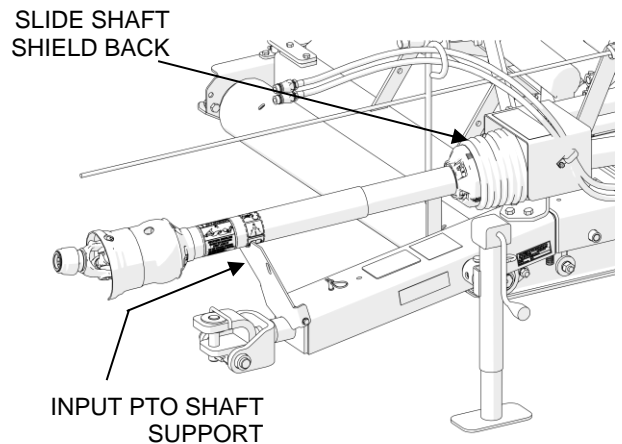

If the PTO shaft comes off during operation, it may cause personal injury and damage to the PTO shaft and tractor PTO. When checking, make sure the locking collar is locked, and that the shaft is not just jammed against the end of the tractor PTO shaft.

## INSTALLING DECK PTO SHAFTS:

The three deck PTO shafts are used to drive the mower decks. Each PTO shaft will have one end designated a tractor end. This end should be hooked up to the main gearbox.

The PTO shafts from the two wing decks must be timed / aligned when mounted to the gearbox. See illustration below. Mount the one side first with the yoke laying flat. The opposite side must be mounted with the yoke laying as flat as possible. ie. Timed. Note it may not be possible to engage the second PTO perfectly aligned to the first, due to positioning of the internal gearing. Position as close as possible.

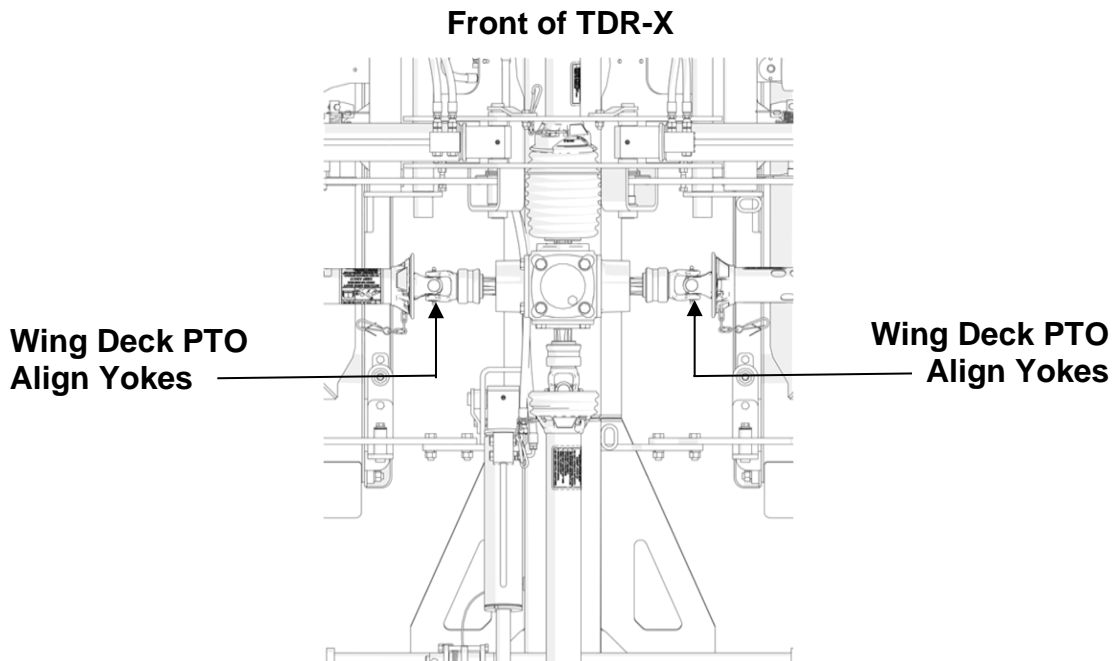

### CAUTION!

All PTO shafts have a short chain attached on both ends. Find a location to wrap or hook on short chain. Be sure that when decks are brought into transport position, the safety chain will not bind or pull PTO shield.

The Intermediate shaft is installed with the large bell end onto the main gear box. The PTO mount bracket is then installed by sliding the PTO end through the flange bearing, leaving the mounting bolts loose. See section on "Hitching to the Tractor"

## **TRANSPORT TIRES**

Check air pressure in the tires and adjust according to specifications

### **Transport Tires – 20 PSI**

The mower is now ready for pre-delivery inspection and lubrication prior to first use.

## MOWER SETUP FOR OPERATION

### WARNING!

Always refer to tractor operator's manual for specific detailed information regarding operation of equipment.

Always ensure the tractor controls are in the park position, the engine is turned off, the parking brake is engaged and hydraulic pressure to the tractor remote connectors has been relieved when working around tractor during setup procedures.

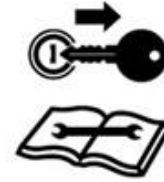

### DRAWBAR ADJUSTMENT

Before hitching the mower to the tractor, ensure tractor drawbar is set properly. Having the proper hitching dimensions for the tractor drawbar and the PTO, will ensure long and trouble free hours of operation. **Incorrect setup may lead to contact between the mower and PTO shaft, causing damage to the Input PTO shaft.**

The decal shown in Figure 1 is mounted to the machine and indicates these important hitch dimensions.

- 1) The drawbar length must be adjusted so it is 14" to 15" from the end of the PTO shaft to the center of the draw pin
- 2) To ensure sufficient clearance, the top of the drawbar must be 6" to 9" from the center of the PTO shaft to the top of the drawbar.

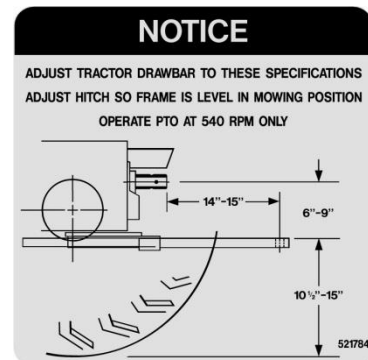

Figure 1

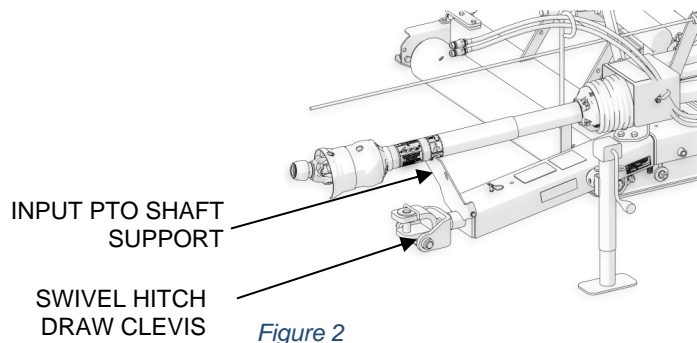

Figure 2

- 3) To assist in connecting the TDR-X to the tractor, the provided hitch pin can be temporarily placed in the hitch swivel to hold it level while aligning the hitch, as shown in Figure 3. Do not operate mower with the hitch pin in the hitch swivel.

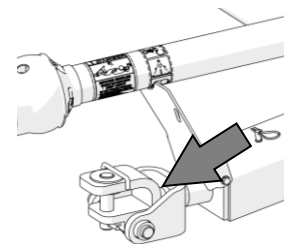

Figure 3

## HITCHING THE MOWER TO THE TRACTOR

### **WARNING!**

**Crushing Hazard between tractor and mower. Never allow anyone to stand between tractor and mower while backing-up to the mower**

- 1) With the draw pin placed in the hitch clevis (Figure 3 page 19), back the tractor to the hitch clevis.
- 2) When the draw pin holes are aligned, place the tractor controls in the park position, shut the engine off and engage the parking brake.
- 3) Remove draw pin from the hitch clevis and place in the draw pin hole connecting the mower to the tractor.
- 4) Note always use the provided hitch pin. The flat top design provides additional clearance to the underside of the input PTO. **Never use hitch pins with D ring type handle.**
- 5) Raise parking jack fully and place in storage position (Figure 4).

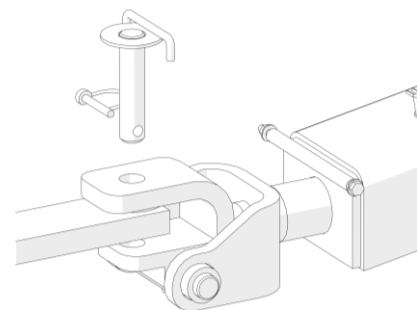

### **STOWING THE JACK**

The jack cannot be stowed in the parked position while mowing. A second storage position is provided on the Left-hand deck to avoid damage to the jack while mowing (Figure 4).

### **CONNECTING THE PTO TO THE TRACTOR**

- 1) Ensure that the tractor engine is shut off, the parking brake is engaged, and the mower is securely hitched to the tractor.
- 2) Lift input PTO shaft from PTO support, ensuring that PTO support swings down and rests on frame tube.
- 3) Slide the mower input shaft locking collar backwards, opening the locking mechanism. Locking collar should remain in an open position
- 4) When it is safe to do so, hold the PTO against the end of the tractor PTO shaft, rotate the PTO by hand until the shaft slides on slightly.
- 5) Slide the yoke onto the tractor's PTO.
- 6) The locking collar should automatically engage when the yoke is properly engaged with the tractor PTO.
- 7) Attempt to move the shaft forward and backwards to ensure that it is securely locked in place.
- 8) Attach the PTO cover safety chain to the tractor. Ensure cover is properly retained by the chain on the mower end.
- 9) The TDR-X is equipped with a PTO support to aid in connecting the mower to the tractor. Once the PTO shaft is connected to the tractor, fold the PTO shaft support down onto the frame and secure it with the supplied cotter pin before operating – **DO NOT LEAVE SUPPORT IN UPRIGHT POSITION.** See Figure 2 page19

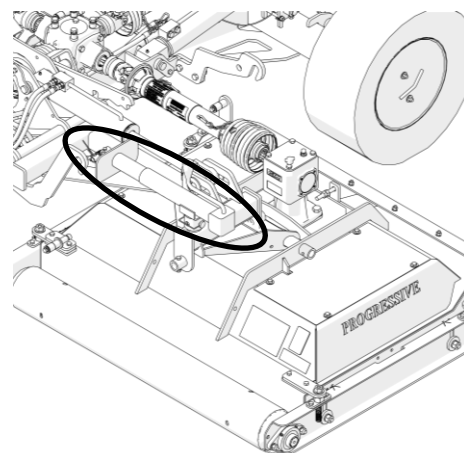

Figure 4

### **WARNING!**

**If the PTO shaft comes off during operation, it may cause personal injury and damage to the PTO shaft and tractor PTO. When checking, make sure the locking collar is locked, and that the shaft is not just jammed against the end of the tractor PTO shaft.**



## WARNING!

Hydraulic fluid escaping under pressure can penetrate the skin causing serious injury. If skin penetration occurs, seek medical attention immediately.



### CONNECTING THE HYDRAULICS

- 1) Ensure the tractor controls are in the park position, the engine is turned off, the parking brake is engaged and hydraulic pressure to the tractor remote connectors has been relieved per the tractor operator's manual instructions.
- 2) When connecting the hydraulic couplers to the tractor, be sure that both ends are clean. Dirt in the hydraulic system can block the orifice in the cylinder and cause premature wear of hydraulic components on the mower and tractor.
- 3) Connect the hose to the A / B ports of the same remote. Hydraulic float function is not required for TDR-X operation.
- 4) Ensure the hoses are free to move, between the tractor and mower and will not become entangled. During operation of the mower the distance between the tractor and mower will change while going up and down hills or during turns.

### CONNECTING THE PULL ROPE

The TDR-X mower is equipped with a nylon pull rope that is connected to the deck release mechanism that is used for locking decks into transport position.

Connect it to the tractor in a position that is easily accessible to the operator and will release easily if the mower should ever become disconnected. Ensure there is sufficient slack between the tractor and mower to allow for proper maneuvering of machine without rope becoming entangled.

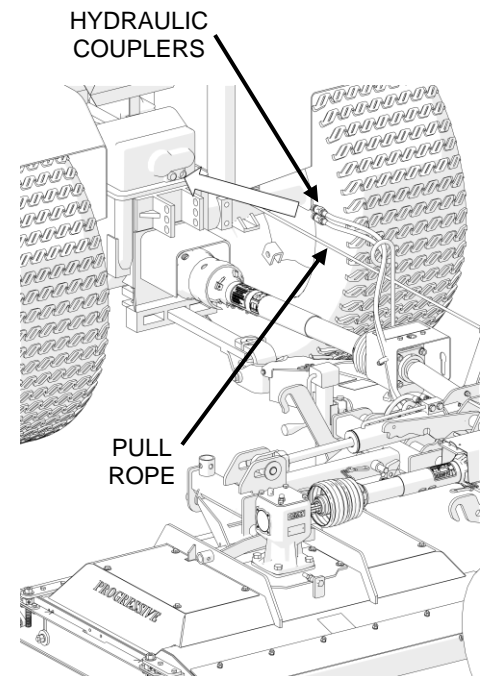

### MOWER SAFETY LOCKS

Safety locks are provided for each deck to prevent unexpected lowering from the transport position in the event of a failure in the hydraulic system.

### DECK LOCK SYSTEM

The deck lock system on the TDR-X mower is a multi-function system controlled by the pull rope and operated by sealed cables.

To unlock the decks from the transport position: PTO not engaged

1. **FIRST**, all decks must be fully raised. This removes pressure from the deck locks so they can release – **this is most important for the rear deck**
2. Operate the hydraulic lever to fully raise the decks removing pressure from the locks.
3. When it is safe to do so, pull and hold the release rope,
4. Lower the three decks

- 4.1. If one deck does not move, STOP, release the pull rope and fully raise the decks again. Repeat step 1.
5. If all decks lower, continue lowering the decks to the ground.
6. Once the decks touch the ground, hold the lever and ensure all three cylinders are fully extended

As with any mechanical system, the lock system needs to be used and maintained properly. With only a few moving parts, this is a simple task.

In a safe level location, fully lower the decks to the ground, shut the tractor engine off, and set the parking brake.

With the lock rope released, all three lock arms should lay flat, resting against the 3/8" bolts. This is critical for proper function of the Pro Lift-N-Turn™ system.(Figure 5)

Check each of the three lock arms and release cams making sure they do not bind when the lock release rope is pulled or released.

Ensure that the lock arms, release cams, cables and springs are in good condition and move freely.

Check to see if the lock release pull arm is free to rotate without binding and returns to a neutral position so that the deck lock arms can lay flat against the wing frame.

If any binding or damage is found, repair the issue before proceeding to use the mower

## **TRANSPORT LOCK**

When the decks are in the fully raised position and the pull rope released (slack), the lock arms engage with each wing and the rear lift to ensure they do not lower when hydraulic pressure is relieved. (Figure 6)

Pro Lift-N-Turn™ Position

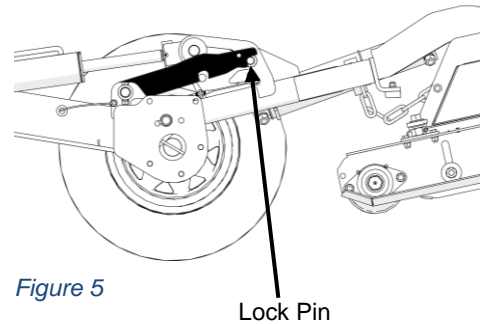

Figure 5

Locked Transport Position

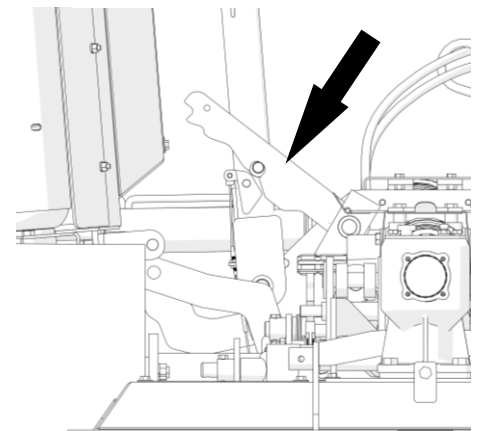

Figure 6

## **! WARNING!**

**Never stand beneath the mower decks when placed in the transport position.**



## CHECK PTO LENGTH - TURNING AND ON HILLS

The TDR-X mower is designed for mowing of uneven, contoured landscape. When negotiating turns, the input PTO shaft will change in length. During mowing of steep contoured conditions, when the tractor starts up a hill the PTO shaft will collapse (shorten) and when cresting the hill, it will extend. It is important to make sure that the PTO shaft does not fully collapse, fully extend or contact the frame or hose support rod during turns or when travelling over hills.

To ensure proper setup check the following conditions:

- 1) With the tractor in the lowest gear and travelling very slowly, make a sharp turn to the right – do not let the CV joint exceed 80 degrees – see Figure 7 page 24.
- 2) Watch the PTO shielding to make sure the PTO shaft does not totally collapse. There should be a minimum of 5 ½" of the inner black PTO shielding exposed at maximum turn.

**NOTE:** This is not the worst condition. Making turns while the tractor is angling up a hill will cause the PTO shaft to collapse even more. Likewise, traveling straight up or down a hill will either extend or collapse the PTO shaft. The operator should avoid making sharp turns on uneven terrain.

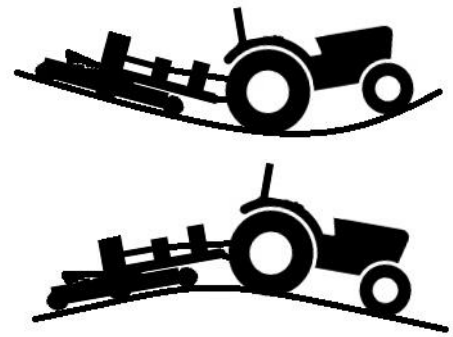

### WARNING!

If the PTO over extends, it will come apart and can cause injury to the operator or damage to the mower or tractor.

### CAUTION!

If the input PTO shaft collapses fully, it will force the shaft back against the hanger bearing. This will cause damage and premature failure of the bearing.

## CV JOINT INPUT SHAFT

Progressive has equipped the TDR-X with an input shaft that contains a CV joint. This design allows the TDR-X to be more agile and maneuverable, while minimizing drive line vibration.

Never allow the CV Joint to exceed an angle of more than 80 degrees or damage will result. See Figure 7.

**Damage can occur more easily when turning as you reverse the tractor**

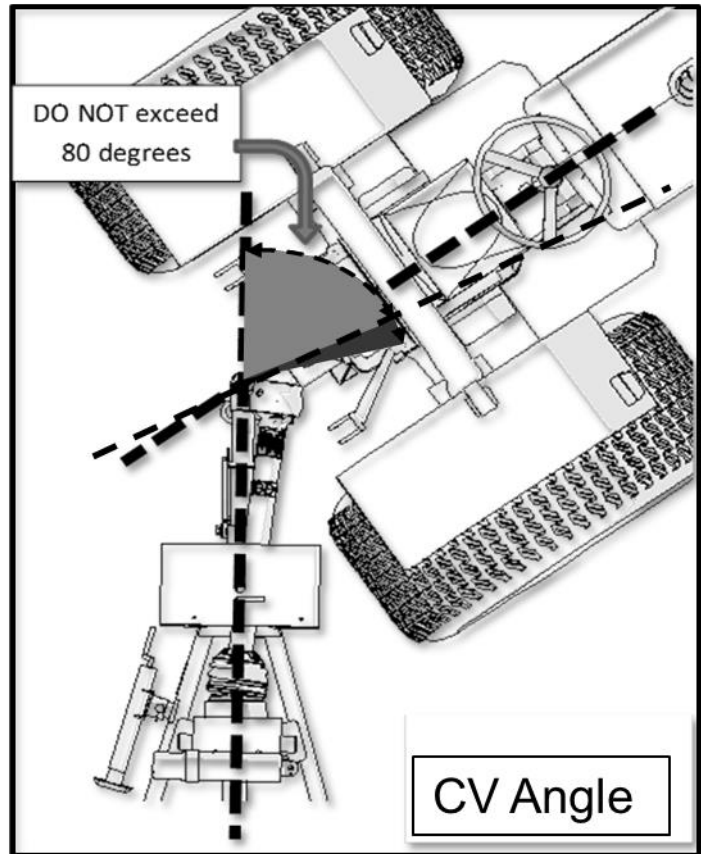

Figure 7

## DISCONNECTING THE MOWER

The mower can be stored with the decks in the raised or lowered position. If the wings or decks are in the raised position, ensure the deck locks are securely engaged before disconnecting the mower from the tractor.

- 1) Place mower on a level surface for storage.
- 2) Ensure that the tractor engine is shut off and the parking brake is engaged.
- 3) Inspect deck safety locks to ensure they are properly engaged (if in the raised position). (Figure 8)

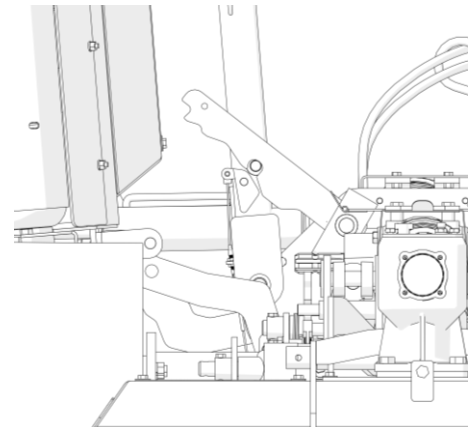

Figure 8

- 4) Do Not pull on the lock release rope; relieve pressure in the hydraulic hoses per tractor manufacturer's instructions (normally cycling the tractor control valve in both directions is sufficient).
- 5) Chock mower transport tires to ensure mower does not roll unexpectedly when hitch pin is removed.
- 6) Disconnect pull rope from rear of tractor and hook on hose support rod.
- 7) Disconnect hydraulic couplers from tractor & stow in supplied locations in the sides of the intermediate shield (Figure 9).
- 8) Disconnect input shaft guard chain from tractor.
- 9) Slide the mower input shaft locking collar backwards, opening the locking mechanism. Locking collar should remain in an open position.
- 10) Remove input shaft from tractor (collapsing sliding shaft) and stow on supplied support bracket (Figure 10).
- 11) Remove the tongue jack from the storage location on the left wing and place in the parking position. Raise the jack sufficiently to remove all mower weight from the tractor drawbar. Ensure mower tongue jack is securely fastened to mower frame with supplied pin before removing hitch draw pin
- 12) Remove supplied draw pin from hitch and stow in the hitch swivel.

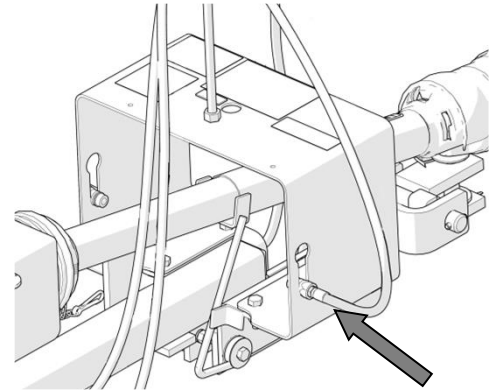

Figure 9

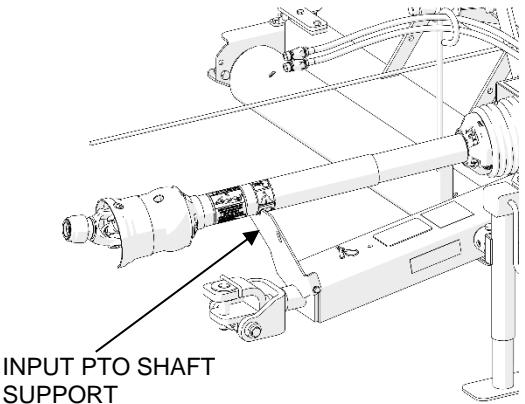

Figure 10

## ADJUSTING THE MOWER FOR CUTTING

### WARNING!

Ensure safety locks are properly engaged before attempting to service mower. Make all adjustments with the tractor turned off, key removed and parking brake set. Mower must be on level ground before making adjustments.



### SETTING HEIGHT OF CUT

There are four height adjusters per mowing deck. Each adjuster (located in each corner of the deck) must be adjusted to the same height to ensure a smooth even cut. In addition, each deck must be adjusted the same so that a level cut is obtained across the whole cutting width of the mower. Mower cutting height adjustment is made by turning a 5/8" nut on top of an acme threaded rod which makes up the height adjuster. A pointer on the side channel indicates the height against the scale. There are an infinite number of adjustments available from 3/8" to 3 3/8". Moving the adjuster up and down moves a side channel that mounts the front and rear rollers. Before attempting to make height adjustments, the locking bolts on the side channels must be loosened. When the desired adjustment is made, be sure to tighten the locking bolts to maintain the adjusted height. The height scales at the back of the deck are set so that the back actually cuts slightly higher, this will provide a better cut, prolong the life of the blades, and reduce horsepower requirement. This will also make the side channel look uneven, but this is correct.

### TDR-X HEIGHT ADJUSTER

1. On flat level ground, place the decks on the ground and fully extend the deck cylinders until they are in the center of the float slot.
2. Shut of the tractor and engage the parking brake. Work on one side of a single deck at a time
3. Using a 15/16" wrench, loosen both side channel lock bolts, do not remove
4. Using a 15/16" wrench adjust Height Adjustment Nut to decided height of cut according to the adjacent scale and indicator.
5. Repeat for the other adjuster on the same side channel – setting it to the same height indication.
6. Securely tighten the two side channels lock bots to retain the cut height
7. Repeat steps 3 to 6 for the other side of the same deck.
8. Repeat above procedure for the remaining decks

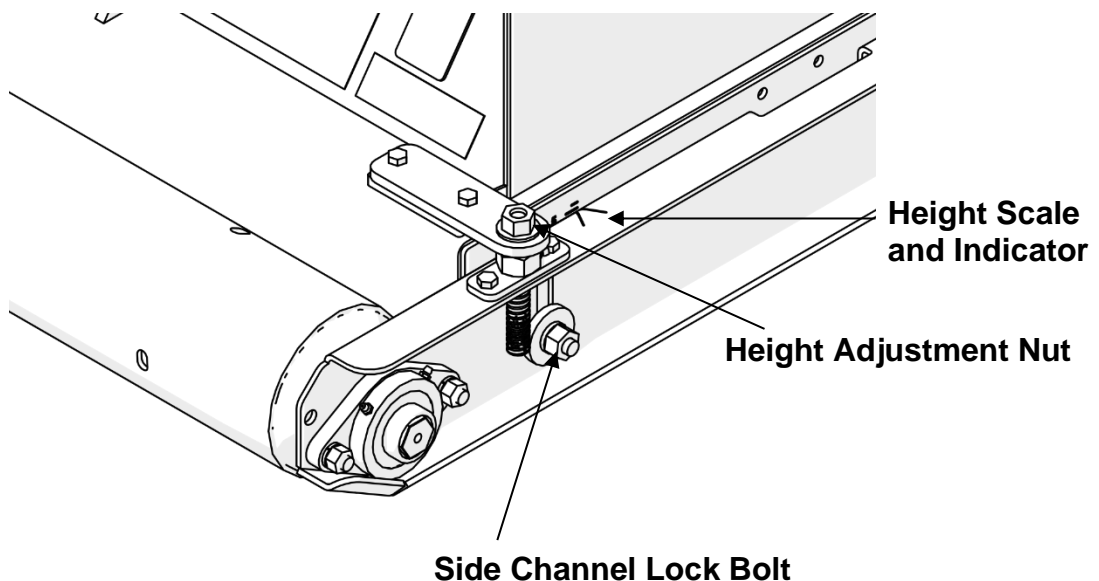



## OPERATING THE MOWER

### DAILY CHECK LIST

1. Always wear relatively tight and belted clothing to avoid entanglement in moving parts. Wear sturdy, rough-soled work shoes. Never operate tractor or implements in bare feet, sandals or sneakers. Ensure other required PPE is in good condition.
2. Ensure all safety shielding is properly installed and check that all nuts and bolts are secure and pins are properly fastened.
3. Inspect all safety decals and ensure they are clean and in legible condition.
4. Inspect deck locks and ensure all pivot points and pull mechanisms have free movement and are in good order.
5. Check condition of blades and security of attachment.
6. Ensure mower is properly connected to the tractor, adjusted and in good operating condition.
7. Be sure deck release pull rope and hydraulic hoses are properly secured and will not become entangled in PTO shaft.
8. Tall grass can hide obstacles. Carefully walk the entire area to be mowed beforehand. Look for debris, rocks, tree limbs etc. that will damage or be thrown by the mower blades. Identify objects that cannot be removed. Set mower cutting height to avoid contact.
9. Never permit any person other than the operator to ride or board the tractor at any time.
10. Check that all lubrication points with grease fittings have been lubricated as per schedule (Figure 13,page 31).
11. Check the gearbox for possible oil leaks.

### RAISING / LOWERING THE WINGS & DECKS

The mower decks are raised into and from the transport position by hydraulic cylinders activated by the tractor's hydraulic circuit.

To lower the wings from the transport position:

1. Ensure the deck transport locks are engaged (Figure 8 page 24).
2. With the tractor running and when it is safe to do so, place the tractor hydraulic control in the raise position **and raise the decks fully**. This removes any tension from the lock arms.
3. Pull the rope and hold in this position (until the decks are fully lowered).
4. Place the tractor hydraulic control in the lower position and lower the wings (while pulling the rope).
5. Lower decks to the ground. Release rope when fully lowered.
6. Hold the hydraulic lever briefly and ensure all three deck cylinders are FULLY EXTENDED (pin mid-way along the float slot). This allows for proper floatation of the decks during mowing. Release the hydraulic lever. Hydraulic float function is not required for proper operation.

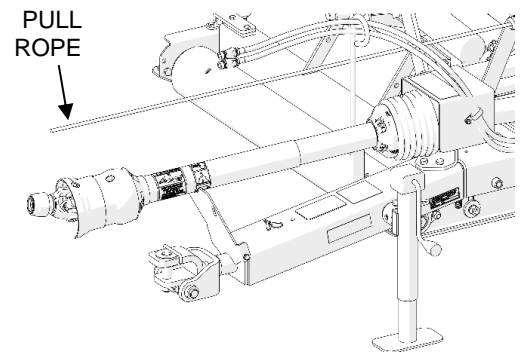

To raise the wings for transport:

1. When it is safe to do so, pull the rope and hold in this position until the wings are fully raised.
2. Place the tractor hydraulic control in the raise position and raise the mower decks fully
3. Release the rope to engage the wing locks for transport (when fully raised).
4. Release the hydraulic lever and make sure the locks are engaged(Figure 8 page 24).

### **ENGAGING THE PTO**

When engaging the mower PTO , it is important to follow this procedure:

- 1) When it is safe to do so, lower mower decks gently to the ground.
- 2) Ensure all deck cylinders are FULLY EXTENDED (pin mid-way along the float slot). This allows for proper floatation of the decks during mowing.
- 3) Release the pull rope.
- 4) Set the tractor engine speed just above idle so the engine will not stall after starting the PTO
- 5) Ensure that everyone is clear of the mower and it is safe to engage the tractor's PTO.
- 6) Engage the tractor PTO.
- 7) Select the proper ground speed gear and slowly engage forward motion.
- 8) Once the mower has come up to speed, slowly increase the tractor throttle to required rpm to achieve 540 PTO RPM speed.

### **MOWING**

The TDR-X mower is a very versatile cutting machine that allows the operator to maintain turf on undulating terrain in a productive manner. Drive safely, cut safely. Be sure to idle the tractor back before engaging or disengaging the PTO, and shut the tractor off before leaving the tractor.

**NOTE:** Under normal cutting conditions, it may be desirable to operate the tractor at less than 540 rpm PTO speed, reducing fuel consumption and noise levels. Select a suitable ground speed gear to maintain proper cut quality.

## Pro Lift-N-Turn™ SYSTEM

The TDR-X is equipped with the Pro Lift-N-Turn™ system. This feature allows the operator to temporarily lift all cutting decks just off the turf without shutting down the PTO. Utilizing the Pro Lift-N-Turn™ system when mowing near cart paths or other roadways, allows the operator to move from section to section without needing to disengage the PTO and raise the decks to the full transport position. Pro Lift-N-Turn™ can also be used to start the mower in tall grass. Engaging the blades with the decks raised will reduce start-up loading on the mower drivetrain.

The Pro Lift-N-Turn™ system is activated automatically when the wings are lowered and the pull rope released. The operator can temporarily lift the mower decks during operation using the tractor hydraulics. Once the mower is again in position to mow, the operator can lower the decks and continue mowing. It is possible to perform this without disengaging the PTO.

### NOTES :

- 1) Always fully extend the Hydraulic cylinders after using Pro Lift-N-Turn™ before mowing for proper float operation.
- 2) Always make sure the locks and lock release cams pivot freely and are in good condition before using this function.

Pro Lift-N-Turn™ engaged on rear deck

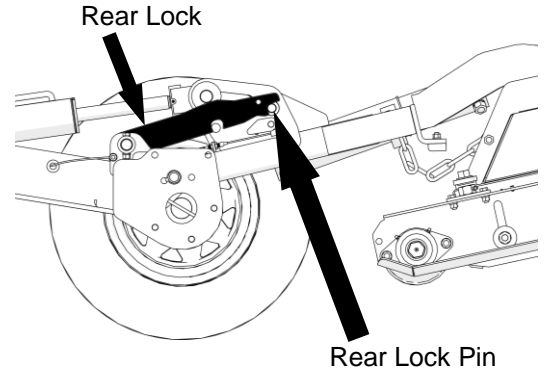

## DANGER!

**The mower blades remain at cutting speed while using the Pro Lift-N-Turn™ system. Do not proceed into areas that may have loose debris that may be thrown by the mower blades.**

**NOTE:** The Pro Lift-N-Turn™ system is designed to be engaged for short durations only. If travelling over long distances with the decks in the raised position, disengage PTO before proceeding.

### MOWING WHILE REVERSING TRACTOR

The unique design of the hitch and deck mounting allows the mower to operate equally well in the reverse direction. This is excellent for cutting in confined areas and cleaning up leaves in the fall.

### OPERATING ON HILLY TERRAIN

When operating on hilly terrain, proceed with caution and drive carefully. If the tractor has four wheel drive, make sure it is engaged. On two wheel drive tractors equipped with a differential lock, apply while driving straight on the hills; disengage to allow for normal turning.

## WARNING!

**Use care while turning on hillsides in wet conditions. The weight of the mower behind the tractor may push the tractor unexpectedly. Drive slowly around sand traps, river banks, etc.**

## **WARNING!**

**NEVER attempt to clear blockages with tractor engine running! Always ensure the engine is OFF and the tractor parking brake is set before clearing blockages.**

### **STOPPING THE MACHINE IN AN EMERGENCY**

All function of the TDR-X mower is controlled through the tractor. In the event of an emergency, follow the measures specified by tractor manufacturer as outlined in the tractor operator's manual.

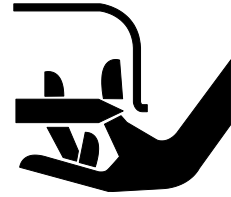

## **TRANSPORTING THE MOWER**

### **WARNING!**

**The TDR-X mower is NOT designed for use on public roadways. Use an appropriate transportation method such as a trailer or float to move mower from site to site if required.**

When transporting the TDR-X from site to site, ensure the decks are in the raised position and deck safety locks are engaged.

### **WARNING!**

**Use an appropriate sized vehicle to tow the TDR-X mower. The tongue weight is 756 lbs, and the total weight is 3250lbs. Make sure that the tow vehicle exceeds these tow ratings.**

## **TIE DOWN LOCATIONS**

(3) Tie-Down provisions are located on the mower per the diagrams below:

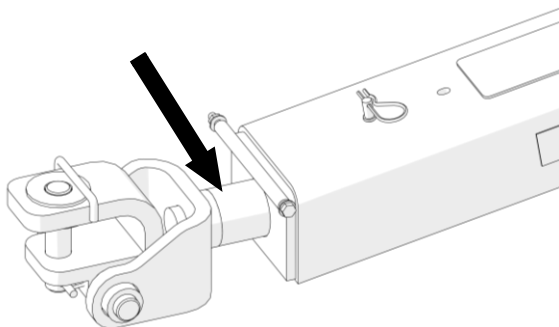

*Figure 12 Tie Down Location Front*

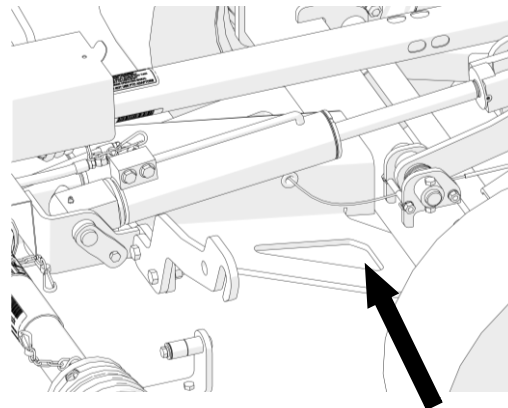

*Figure 11 Tie Down Location Rear*

# MAINTENANCE

## WARNING!

Ensure the tractor controls are in the park position, the engine is turned off, the parking brake is engaged and hydraulic pressure has been relieved before performing service or maintenance.

Perform all maintenance with the wings and mower decks in the lowered position and the machine on a flat and level surface.

Always use personal protection devices such as protective glasses and face shields, protective shoes, gloves, hard hats, and ear protection when performing service or maintenance functions.

When completing a maintenance or service function, make sure all safety shields are installed before placing mower in service.

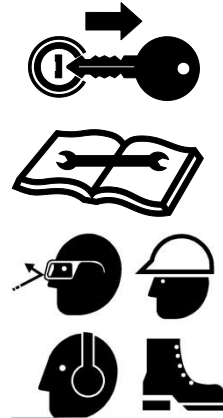

		Maintenance Intervals					
		Initial Run / 50h	Daily	Weekly or 50h	100h / Monthly	600h / Yearly	Removal from Storage
Grease	Intermediate Hanger Bearing	-	-	X	-	-	X
	Locks, Lock Release, Lock Cams	-	-	-	-	-	X
	Deck Pivots, Deck Swivels, Wings	-	-	-	-	-	X
	HEX Roller End Bearing	-	-	X	-	-	X
	Transport Wheels	-	-	-	X	-	X
	Input PTO Shaft (10 locn's)	-	-	-	X	-	X
	Intermediate PTO Shaft (3 locn's)	-	-	-	X	-	X
	Deck PTO Shaft ( 7 locn's)	-	-	-	X	-	X
Oil	Inspect Gearbox - All	-	X	-	-	-	X
	Check Gearbox Oil - All	-	-	-	X	-	X
	Change Gearbox Oil - All	X	-	-	-	X	-

Figure 13

Notes:

- 1) Always grease the PTO safety shield collars when greasing the shaft

## LUBRICATION

A properly maintained lubrication schedule will provide a smooth running machine for many years. The following information shows and describes where lubrication points are located and what types of lubricant are required.

### GREASE SPECIFICATIONS

**All greases are not compatible. Grease incompatibility will decrease the lubrication ability of the grease, and can cause premature part failure.**

Grease can have mineral or synthetic base oils and thickening agents such as lithium, calcium, barium, sodium, or aluminum

What We Use:

- Progressive uses Shell Gadus S2 V220 2
- This grease has:
  - A mineral oil base
  - A lithium-12 hydroxy thickener ("lithium" thickener)
  - Extreme Pressure additives (EP)
  - An NLGI Grade 2

### Recommended Grease Properties

The grease you use for this machine must have these properties:

- NLGI grade 2
- Lithium thickener (NOT LITHIUM COMPLEX)<sup>1</sup>
- Kinematic Viscosity at 40°C is no greater than 220 cSt
- Dropping Point Less than 400° F
- General Purpose Grease, Not Heavy Duty
- **No MOLY (molybdenum disulphide) additives in the grease<sup>2</sup>**
- **No synthetic grease<sup>3</sup>**
- **No High Temperature Grease<sup>4</sup>**

Notes on grease compatibility:

- 1) If a thickener other than lithium is used (including lithium complex), the existing grease will be contaminated and the lubrication properties may be lost leading to component damage.
- 2) Molybdenum Disulfide (Moly) is an additive used in slow moving, extreme load applications. The particles in the "Moly" will actually increase bearing wear in a high speed mower application. Generally speaking Moly based greases will be grey in colour.
- 3) If synthetic base oil is used rather than mineral base oil, the grease will be contaminated; the lubrication properties may be lost leading to component damage.
- 4) We do not recommend the use of "High Temperature" greases, mower component temperature should never reach temperatures above the level at which general purpose greases can operate. "High Temperature" greases may contain thickeners that are not compatible with Lithium-12 Hydroxy based thickeners.

Grease with these features is considered to be a "General Purpose Grease". Use on all grease point locations on your Progressive Mower. Check the properties of the grease you wish to use with your supplier prior to use.

**DRIVELINE GREASING**

All PTO shafts on the TDR-X mower feature 100h greasing intervals. The following decal is located on the mower as a reminder.

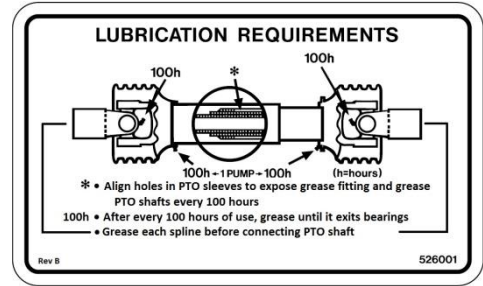

**! CAUTION!**

Failure to properly lubricate the telescoping shaft sections will lead to binding of the shaft and damage to the mower or tractor driveline.

**INPUT SHAFT – 100h / Monthly (10 Locations)**

Shaft must be disconnected from tractor and collapsed fully for greasing

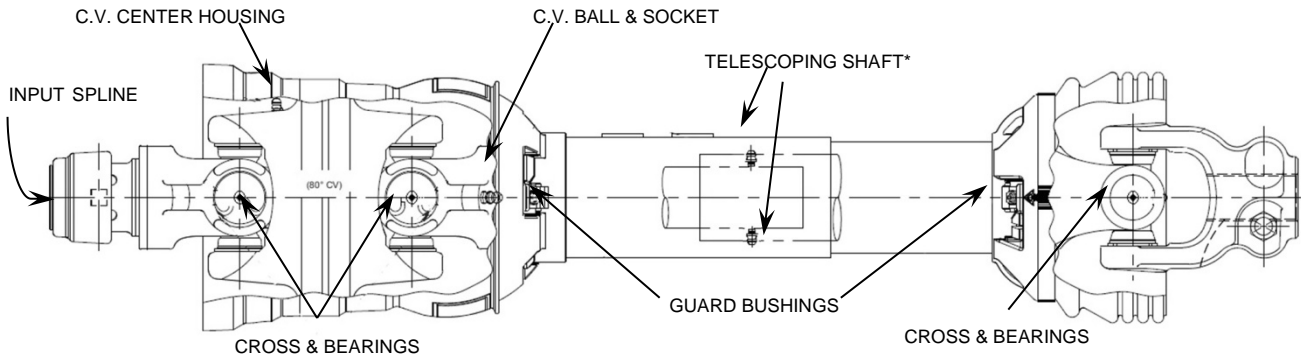

\* Inner & outer guards must be rotated to align holes for accessing the two telescoping shaft grease fittings.

**INTERMEDIATE SHAFT – 100h / Monthly (3 Locations)**

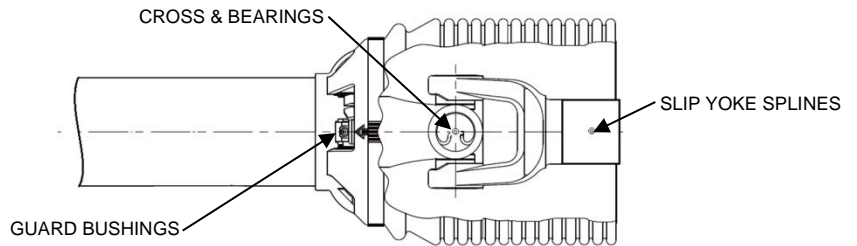

**DECK SHAFTS – 100h / Monthly (7 Locations - 3 Shafts)**

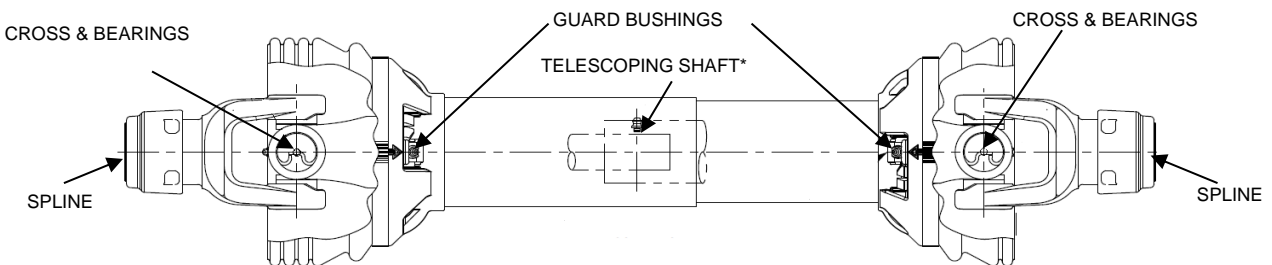

**INTERMEDIATE BEARING – 50h / Weekly (1 Location)**

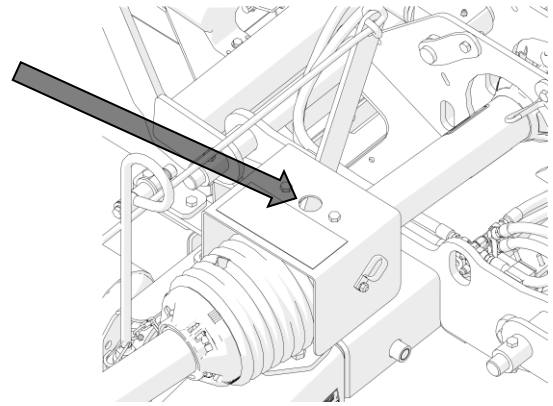

**ROLLER-END BEARING 50H / Weekly (12 Locations)**

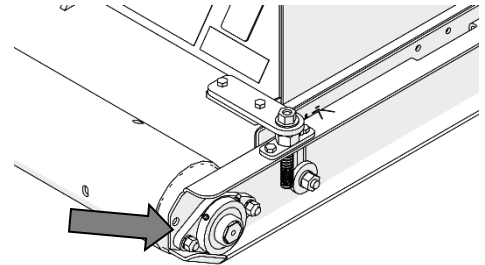

**TRANSPORT HUBS: 100h / Monthly**

The transport wheel hubs have greaseable tapered roller bearings. They should be inspected frequently and lubricated as required.

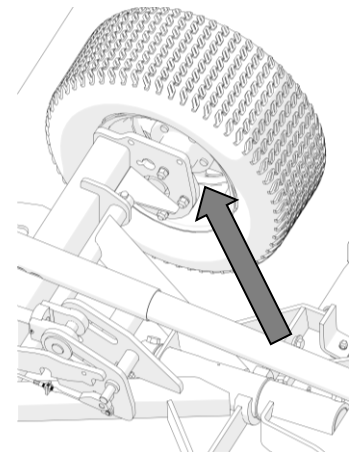

**CHECK OPERATION OF LOCK SYSTEM**

In a safe level location, fully lower the decks to the ground, shut the tractor engine off, and set the parking brake.

1. With the lock rope released, all three lock arms should lay flat, resting against the 3/8" bolts. This is critical for proper function of the Pro Lift-N-Turn™ and wing lock system (For more information see page 29)
2. Have a helper pull and release the pull rope/lock release arm and verify that lock release cams move freely. If they do not, disassemble, clean, inspect and grease, replace bushings if necessary
3. Ensure that the lock arms move freely. If they do not move freely, disassemble, clean, inspect and grease. Replace bushings if necessary.
4. Lock release springs (under main frame) should be replaced every 2 seasons to ensure trouble free operation of the lock system. Kit part number 214022.

If any binding or damage is found, repair the issue before proceeding to use the mower

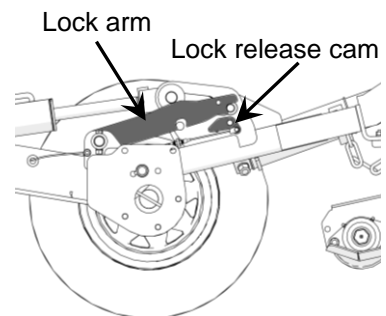



**GEARBOX OIL:**

Recommended Oil: SAE 90 EP or SAE 80W90 EP  
 Factory Fill: Shell Spirax HD SAE 80W90

**⚠ CAUTION!**

**MOWER MUST BE LEVEL** when checking oil level

**DO NOT OVERFILL!** Gearbox may over-heat causing premature component damage.

**4-WAY GEAR BOX**

**Checking Level – 100h / Monthly**

A screw-in dipstick is provided on the top of the gear box. Proper oil level is set when oil is between the marks on the dipstick. If the level is low, add oil through top plug until correct level is attained. Replace and tighten plug.

**Changing Oil - 600h / Yearly**

The gearbox oil should be changed after the first 50 hours of operation and every 600 hours or yearly afterwards.

Oil change quantity – 1.48 Qt (1.4 Litres)

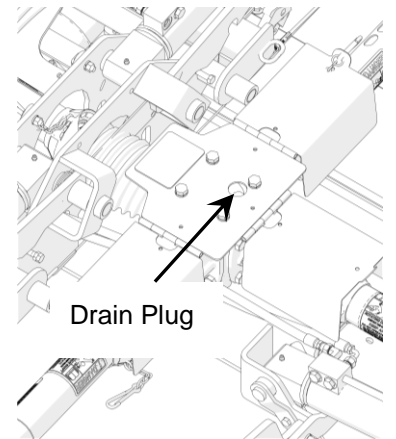
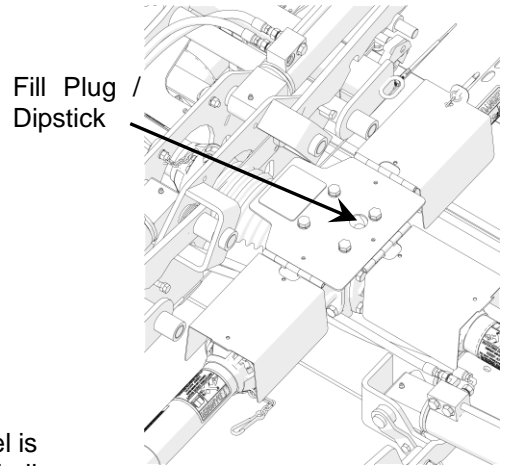

**DECK GEAR BOX (all 3 decks)**

**Checking Level – 100h / Monthly**

The three deck gear boxes have a combination filler plug and dipstick. Remove the plug, dry off the dipstick and replace to check oil level. It must touch the oil in the gear box. Replace oil. Use 80W90 gear oil or equivalent. Reinsert the dipstick and screw in fully. Do not over tighten.

**Changing Oil - 600h / Yearly**

The gearbox oil should be changed after the first 50 hours of operation and every 600 hours or yearly afterwards.

Oil change quantity – 0.85 Qt (0.8 Litres)

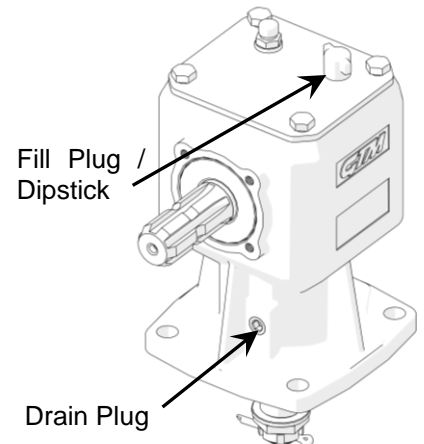

## “V” BELT DRIVE

### “V” BELT TENSION:

Proper belt tensioning is a fundamental factor in the successful V-belt operation. Lack of tension will cause slippage, and too much tension will cause excessive belt stretch as well as damage to the drive components, such as bearings and shafts. Therefore, to ensure proper belt tension, the following procedure is recommended.

### “V” BELT ADJUSTMENT

All deck drive belts utilize a threaded adjuster connected through the deck gear box mount. Tension of both drive belts per deck is set with one adjustment.

In the event that belt adjustment must be made, follow these steps:

- 1) Loosen the jam nut on the adjusting screw.
- 2) Loosen the (4) bolts fastening the gear box slide plate to the mower deck.
- 3) Set desired belt tension by turning the adjusting screw:  
 Clock Wise to tighten belts  
 Counter Clock Wise to loosen belts
- 4) Tighten the (4) bolts fastening the gear box slide plate to the mower deck.
- 5) Tighten jam nut on the adjusting screw.
- 6) Verify proper tension is achieved per “V” Belt Tension section above.

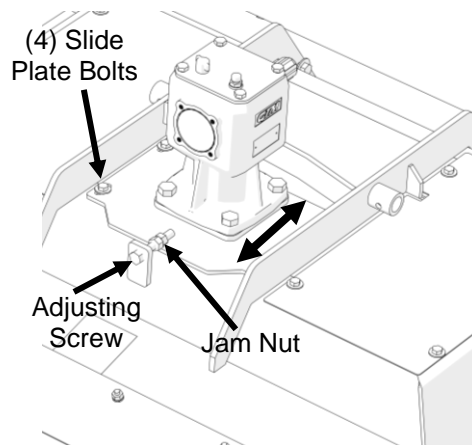
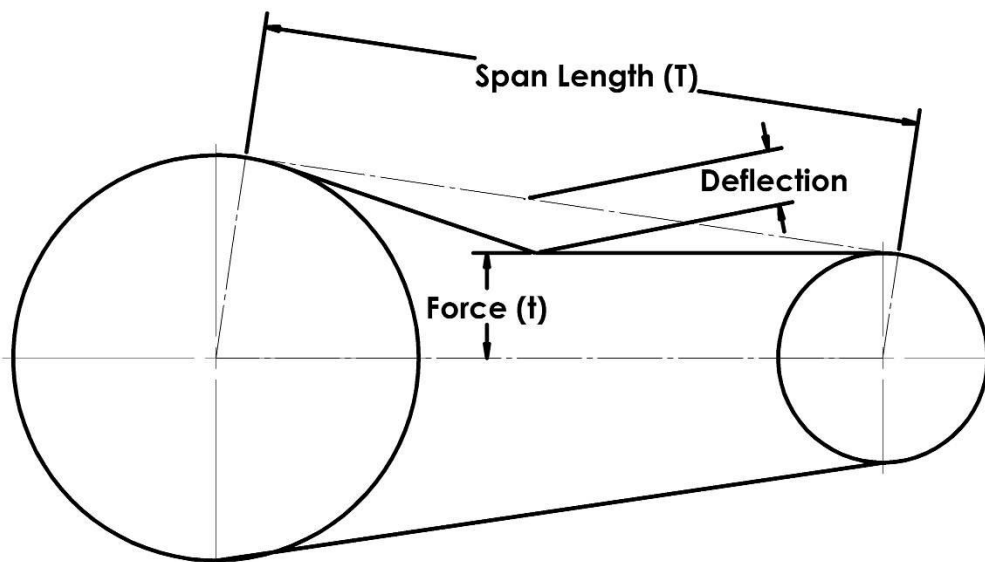

Figure 14



### CHECKING BELT TENSION

At the mid-point of the span, apply a deflection force with a spring scale in the direction perpendicular to the span until the belt is deflected the 3/8”.

The recommended force to deflect the belt is a minimum of 4.9 lbs. to a maximum of 7.3 lbs.

The first 24 to 48 hours of operation is the belt “run in” period. To ensure satisfactory belt performance, belt tension should be checked during this time period.

## FASTENER INSTALLATION TORQUE

The chart below lists the proper installation torque for fasteners on Progressive Turf Equipment mowers. When bolts are to be tightened or replaced, refer to this chart to determine the proper torque (unless otherwise specified in this manual).

SAE Grade 5 (Imperial) and Class 8.8 (Metric) fasteners are to be used in the assembly of this machine, unless otherwise specified in this manual.

### Bolt Grade / Class Identification



SAE Grade 2  
(No Dashes)



SAE Grade 5  
(3 Dashes)



SAE Grade 8  
(6 Dashes)



Class 8.8  
(Metric)

Bolt Diameter (in.)	Recommended Torque in Foot Pounds (Newton-Meters)
5/16	21 (28)
3/8	38 (52)
7/16	55 (75)
1/2	85 (115)
9/16	125 (170)
5/8	175 (240)
3/4	300 (410)
1" LH Spindle Nut	60 (82)
M10	31 (42)
Transport Tire Lug Nuts	100 (135)

## BLADE SERVICING

### WARNING!

Always observe proper lock-out procedures when performing any maintenance work including changing or servicing the blades. Always remove and retain the ignition switch key, ensure parking brake is engaged, and block and or support machine using equipment designed for the task.

Be sure deck and wing safety locks are engaged when working on decks in the raised position.

Use gloves when handling mower blades. Blades can be very sharp.

Inspect blades before each use to determine that they are mounted tightly and are in good condition. Replace any blade that is bent, excessively nicked, worn or has any other damage. Small nicks can be ground out when sharpening.



### WARNING!

Use only original equipment blades when replacing worn out mower blades. They are made of special steel alloys and subjected to rigid heat-treat and inspection requirements. Substitute blades may not meet these specifications and **MAY BE DANGEROUS**.



## BLADE SELECTION

We offer different blade styles for use with this mower:

### Fixed high lift

Combined with Progressive's high tip speed, the fixed High-Lift blade 'stands' grass blades up for a clean cut, even in damp conditions or at high mowing speeds.

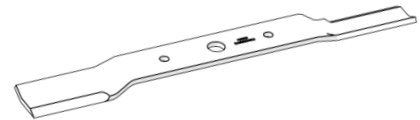

### Pro-EZII Change System (Available in high or low lift)

Developed with turf professionals in mind:

- Economical as only the tips are changed
- Flat profile fastener extends life, reduces cost
- Standard hand-tools are used for reduced cost and easy change out
- Lower start-up torque requirement reduces stress on the complete drive train
- Thinner profile than a standard blade means the tips retain their sharpness after the equivalent number of mowing hours

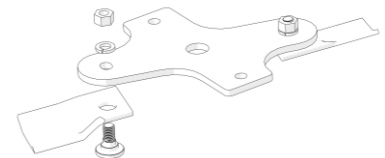

Pro-EzII Blade System installs on the same blade support bar as a fixed blade. This allows users to easily swap blade types as growing conditions or mowing requirements change.

### FIXED BLADE REMOVAL AND INSTALLATION

A 1" diameter pilot centers the blade of the Pro-EZII blade holder on the spindle with two 1/2" grade 5 fasteners. When changing blades, be sure that pilot is properly seated in the blade and the blade lies flat on the spindle bar.

Always replace bolts, lock washers and nuts when replacing blades. Tighten bolts to proper torque as listed on Page 37.

Replace any blade that is bent, nicked deeper than 1/4", excessively worn or has any other damage. Small nicks can be ground out during sharpening. Always balance blades before use.

In abrasive soil conditions, monitor condition of the blade wing. If erosion of the steel is evident at the base of the wing, replace blade.

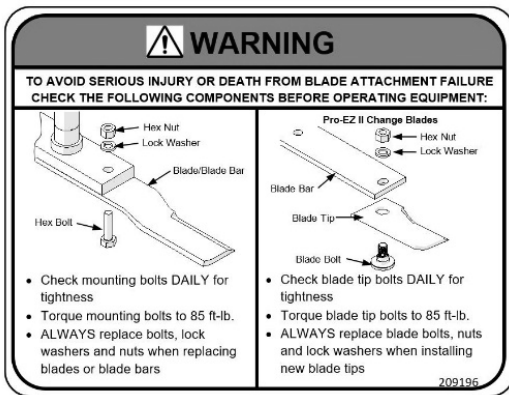
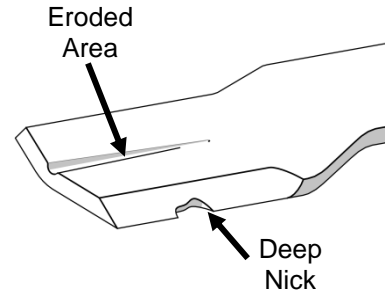

### PRO-EZII BLADE REMOVAL AND INSTALLATION

#### Pro-EZII Blade Bar

A 1" diameter pilot centers the blade bar on the spindle with two 1/2" grade 5 fasteners. When changing blades, be sure that pilot is properly seated in the blade bar and the blade bar lies flat on the spindle.

Always replace bolts, lock washers and nuts when replacing blade bars. Tighten bolts to proper torque as listed on Page 37.

Replace any blade bar that is bent, worn or has any other damage.

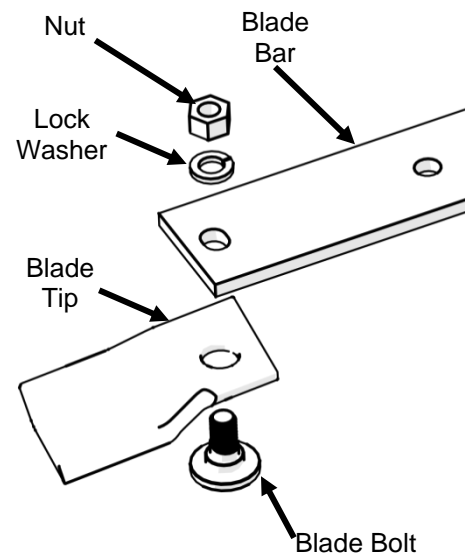

**Pro-EZII Replaceable Blade Tips**

The Pro-EZII change blade tips are serviceable with a single wrench. An anti-rotation slot engaging the blade bolt to the blade bar allows for installation and removal of the nut from one side without having to hold the bolt.

When removing blade tips, inspect the tips and blade bolts for wear and damage.

Replace any tip that is bent, nicked deeper than 1/4", excessively worn or has any other damage. Small nicks can be ground out during sharpening. Always balance Pro-EZII blades as an assembled unit. Replace both tips at the same time on one holder.

Replace any blade bolts that have the head or blade shank worn beyond the limits shown in the accompanying illustrations.

Always install new blade bolts, lock washers and nuts when installing new blade tips. Tighten bolts to 85 ft-lbs **Error! Bookmark not defined..** DO NOT OPERATE WITH ONLY ONE BLADE TIP INSTALLED.

Grass build-up between the tip and blade bar may prevent the tip from pivoting properly at start-up or during mowing. Ensure all tips are free to rotate prior to operation.

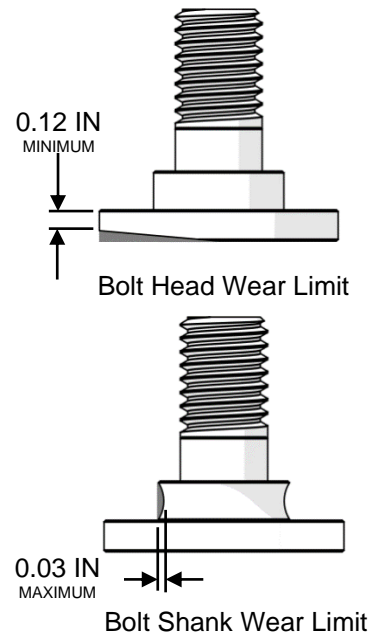

**BLADE SHARPENING**



**WARNING!**

Use gloves when handling mower blades. Blades can be very sharp.

IMPORTANT! When sharpening blades, be sure material removed is equal on both sides of the blade. Unbalanced blades will cause excessive vibration leading to cracks in machine components.

- Clean all material from the blade prior to sharpening and balancing.
- Grind or file blades following original pattern as shown.
- Sharpen to a razor edge. Do not sharpen back side of blade.

Use the supplied cone balancer to verify blade balance. When the blade is correctly balanced, the blade will remain horizontal on the cone balancer as show in Figure 16.

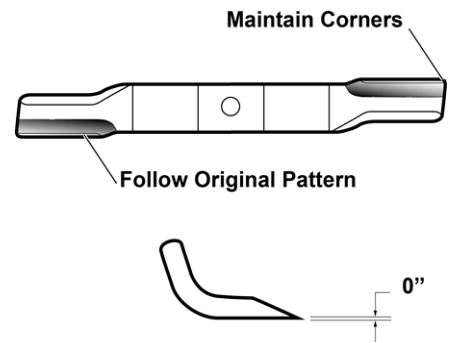

Figure 15– Grind Pattern



**WARNING!**

Failure to properly balance blades after sharpening can cause vibration leading to premature component damage.



Figure 16



**WARNING!**

Wear appropriate eye and face protection when sharpening blades.



## **SPINDLE SERVICE**

Blade spindles are factory equipped with sealed, maintenance free bearings. These spindles are identified by the absence of a grease fitting in the center of the drive pulley.

Periodically inspect blade spindles by removing the belts and spinning the blade spindle by hand to make sure it rotates smoothly, and there are no tight spots.

### **SPINDLE ASSEMBLY REMOVAL**

1. Remove blade from spindle.
2. Remove belt shield. Loosen 4 bolts that hold gearbox slide plate to deck.
3. Loosen 1/2" x 3 1/2" tap bolt and slide gearbox toward front until belt is easy to remove, as shown in Figure 14
4. Remove belt.
5. Remove 4 bolts attaching spindle assembly to mower deck and remove as a unit, since pulley will come out through the hole in the deck.

### **SPINDLE ASSEMBLY INSTALLATION**

Reverse above procedure. Be sure spindle mounting area of deck is clean of any foreign material before attaching spindle assembly.

### SPINDLE ASSEMBLY REPAIR

Note: A video showing this rebuild procedure is available on our website:  
<http://www.progressiveturfequip.com/service>



## CAUTION!

Spindle repair requires special skills and tools, a shop press is required. If your shop is not properly equipped or your mechanics are not properly trained in this type of repair, complete spindle assemblies are available as service parts.

- 1) Remove LH thread nut (1), lock washer (2), pulley (3), key (11) & shim (4,5) from spindle assembly. **The spindle nut is left-hand thread, the pulley has 2 setscrews.**

## CAUTION!

Make sure that the press ram and bed 100% square to each other. If bearings are not square in housing, bearings will wear out prematurely.

- 2) Place assembly in shop press with support under spindle housing flange and press spindle (12) down through housing.
- 3) Remove bottom bearing from spindle and top bearing from housing
- 4) **IMPORTANT! Removing bearings from spindle / housing causes permanent damage to the bearings. New bearings must be used in re-assembling the spindle.**
- 5) Replace bearing spacer tube (8) with new spacer tube if the ends are worn.
- 6) **IMPORTANT! Failure to replace a worn or damaged spacer will lead to premature bearing wear.**

### REASSEMBLY

- 7) Place housing (7) in press (upside down). **Pressing on the outer race**; install bottom bearing (9) into housing.
- 8) Place spindle (12) in press. Install bottom cap (10) on spindle.
- 9) Turn housing right side up, **Pressing on the inner race** of bottom bearing, press housing / bearing on to spindle. A steel tube will be required to slide over the spindle and press on inner race.
- 10) Install bearing spacer (8) with hole end up.
- 11) Set top bearing (6) on to spindle. **Pressing on inner race**, press top bearing on to spindle.
- 12) **IMPORTANT! Due to design tolerances, the top bearing may appear to be loose in the housing. This is normal and is not detrimental to the operation of the spindle.**
- 13) Install shim washer (5), cap (4), key (11), pulley (3) on to spindle.
- 14) Tighten pulley set screws.
- 15) Install LH lock washer (2) and LH nut (1) and torque to 60 ft-lb.

Rotate the housing six revolutions by hand and check for smooth, free movement.

The assembly is now ready for installation into the mower deck.

Note: Orientation of genuine OEM maintenance free bearings are not important. Do not use greaseable bearings in this assembly.

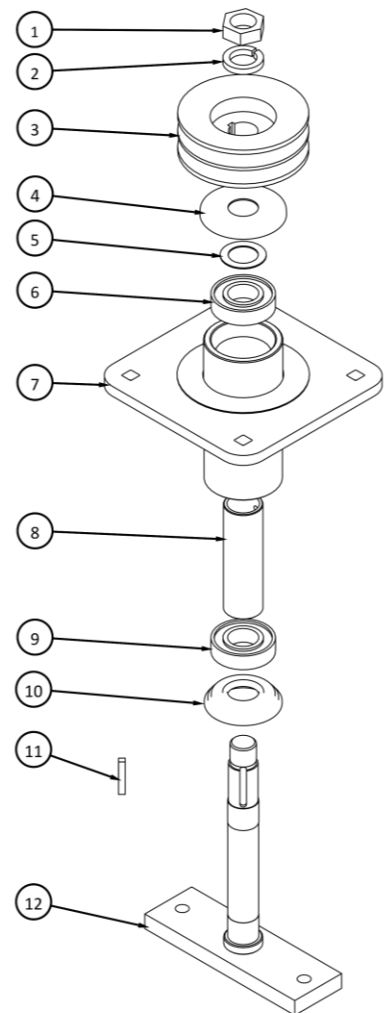



## HYDRAULICS

Hydraulic Oil – Conventional Anti-Wear Tractor-Hydraulic Fluid

Biodegradable Oils – Consult Factory for compatibility analysis.

### WARNING!

**Hydraulic fluid escaping under pressure can penetrate the skin. Seek medical attention at once if injured by escaping fluid.**

During your daily inspection, repair all leaks before they create a major problem. Do not use your hand to check for hydraulic oil leaks. Use a piece of cardboard instead. Hydraulic fluid escaping under pressure can penetrate the skin causing serious injury. If skin penetration occurs, seek medical attention immediately. Relieve all pressure before disconnecting hoses.

When servicing any hydraulic component of the mower ensure that all decks and wings are in their lowered position and all hydraulic pressure is relieved. Pressure can be maintained in the hydraulic circuits long after the power source and pump have been shut down.

Relieve all pressure before disconnecting hoses or tubes.

Tighten all connections before applying pressure.

When connecting the hydraulic couplers to the tractor, be sure that both coupler ends are clean. Dirt in the hydraulic system can block the orifice in the cylinder ports or cause premature wear & failure of hydraulic components on the mower or tractor.

All hydraulic cylinders have a .032" diameter orifice installed in the port for the rod end of each hydraulic cylinder. This orifice is present to throttle the cylinder speed to a safe level. When repairing the hydraulic system ensure that this orifice elbow is present and free of debris that could block the orifice.

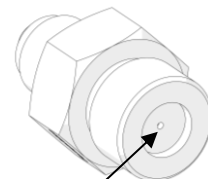

ORIFICE

## SUPPORTING MACHINE FOR SERVICE

You may be required to lift the mower off of the ground for servicing the transport tires / wheels / bearings. Use a bottle or service jack to raise the wheel from the ground and place a wooden block or other suitable support under the rectangular tube.

Jack up the frame in the location shown in Figure 17

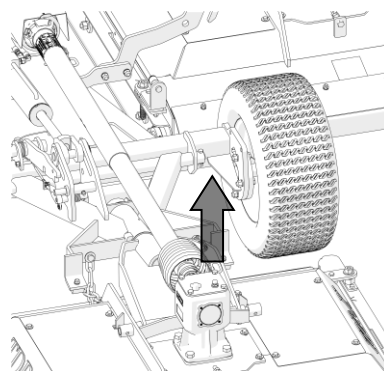

Figure 17

### **WARNING!**

Do not support the machine on cinder blocks, hollow tiles or other members that may fail under continuous load.

Never perform service on a machine that is supported solely by a jack. Always ensure proper blocking is placed to support load during service.

Transport tires must be changed with the wing decks on the ground.

## TRANSPORT TIRES

Inspect tires daily for wear or damage. Check tire pressures weekly with an accurate pressure gauge. Do not inflate tires beyond 20 psi. NOTE THAT THE TIRES ARE NOT HIGHWAY RATED

### **WARNING!**

Mounting and dismounting tires from rims can be dangerous and should be performed by trained personnel using correct tools, equipment, and procedures.



## LONG-TERM STORAGE

If the mower is not to be used for an extended period of time (4 months or longer) it is recommended that the following maintenance steps are followed:

- 1) Thoroughly wash mower, removing all grass clipping residue from deck undersides & mower framework.
- 2) Add grease to all grease points.
- 3) Check gearbox oil for proper level.
- 4) Relieve tension on all V-belts by loosening the bolt on the deck gear box.
- 5) Inspect all drive belts & pulleys.
- 6) Inspect all blade spindle bearings for excessive play.
- 7) Inspect all blades for serviceable condition.

When returning the mower to service after long-term storage:

- 8) Check tightness of all blade fasteners.
- 9) Add grease to all grease points.
- 10) Tension all V-belts.
- 11) Ensure all pivot points move freely.
- 12) Change gearbox oil.

<b>TROUBLE SHOOTING</b>		
<b>PROBLEM</b>	<b>CAUSE</b>	<b>REMEDY</b>
Belt slippage	Lack of tension	Inspect & check tension adjustment as required
	Oily drive conditions	Clean drive
	Over Loading	Increase cutting height or reduce ground speed
Rapid belt wear	Belt slippage	See Above
	Belt not aligned properly	Check pulley alignment and proper spacers
Belt squeal	Belt slippage	See Above
Over-heated bearings	Belt slippage	See Above
	Insufficient Cooling	Remove deck shields and clean out all grass.
Mower Deck will not lower.	Orifice in cylinder plugged	Remove orifice and remove obstruction and reassemble
Vibration on turning	Drawbar length incorrect.	Adjust drawbar to specification
Damage to intermediate bearing or tractor PTO shaft	Input shaft does not collapse easily under power	Remove input shaft, pull apart and deburr / grease splines Grease at proper interval.
Premature spindle bearing failure	Water ingestion from washing	Rebuild spindle with OEM repair kit DO NOT wash down mower when spindle housings are warm
	Improper rebuild procedure	See specific instructions in manual
	Improper bearings	Use only OEM bearings



# Parts List

## TDR-X

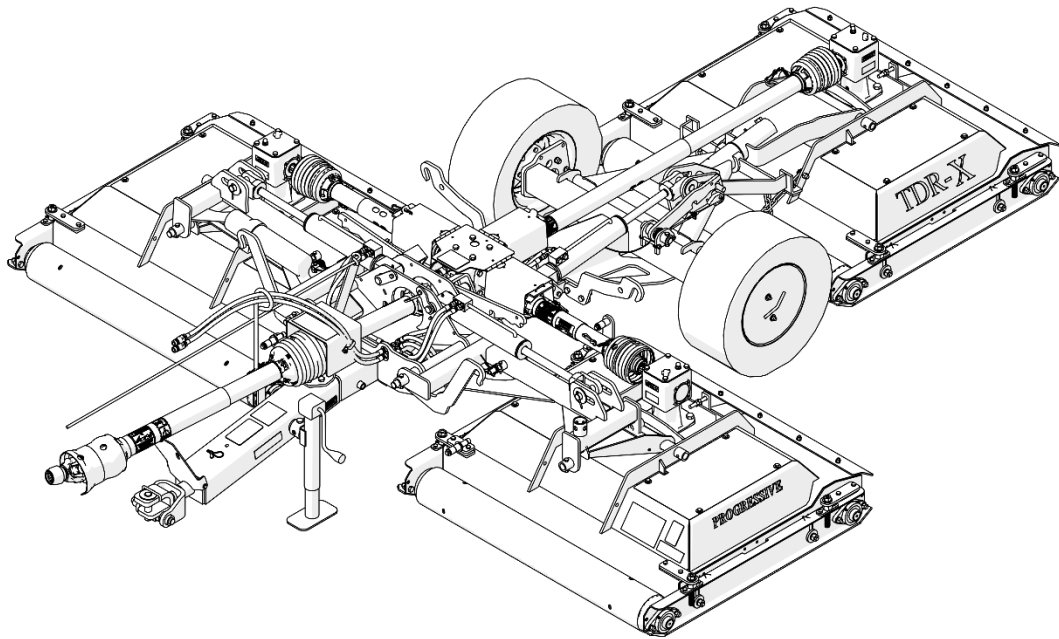

 **DANGER!**

Si No Lee Ingles, Pida Ayuda a Alguien Que Se Lo Lea  
Para Que le Traduzca Las Medidas de Seguridad

Effective serial numbers:  
TDR-X: 20111003 and up.

P.N. 120596

Issue Date: October 2020



## Serial Number Location

The serial number plate for the machine is located on the left side of the main frame tube at the front of the machine.

For quick reference, record the following information:

Model: \_\_\_\_\_

Serial Number: \_\_\_\_\_

Date purchased: \_\_\_\_\_

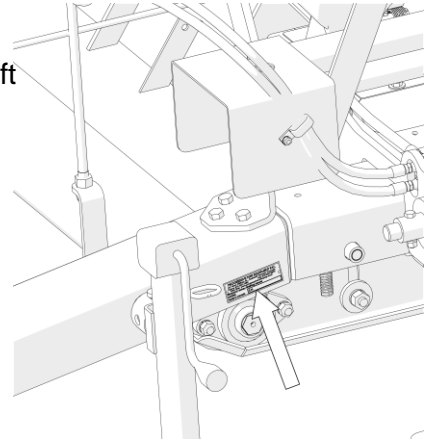

<b>PROGRESSIVE TURF EQUIPMENT INC.</b> 137 West William St., Seaforth Ontario Canada Phone 519-527-1080 Fax 519-527-2275 Web Site: www.progressiveturfequip.com	
<b>PRODUCT: Rotary Finishing Mower</b>	
<b>MODEL:</b>	<input type="text"/>
Made In Canada	<b>S.N.</b> <input type="text"/>

Always state this information when contacting your selling dealer and when ordering spare parts.

## Parts Information

Use only Genuine Original Equipment Manufacturers (O.E.M.) replacement parts. The use of "will fit" parts may reduce machine performance, void machine warranties and present a safety hazard. Use Genuine OEM parts.

## Progressive Turf Equipment Inc.

137 West William Street  
 Seaforth, Ontario  
 Canada  
 N0K 1W0

Phone: 800-668-8873

Fax: 519-527-2275

[www.progressiveturfequip.com](http://www.progressiveturfequip.com)

## Maintenance

Maintenance should always be performed by a qualified service technician familiar with servicing similar equipment, using good safety and workmanship practices.

**Always observe proper lock-out procedures when performing any maintenance work.** Other than maintaining the blade spindles or blades, always lower all decks before performing maintenance. Block and or support machine using equipment designed for the task. When maintaining blades or spindles, always ensure locks are seated correctly in place. When performing hydraulic maintenance, ensure that pressure has been released.

It is imperative that the operator or qualified service technician reads and understands all the safety information in the Operator's Manual before proceeding. Failure to follow the instructions or heed the warnings could result in injury or death. **Proper care is your responsibility.**

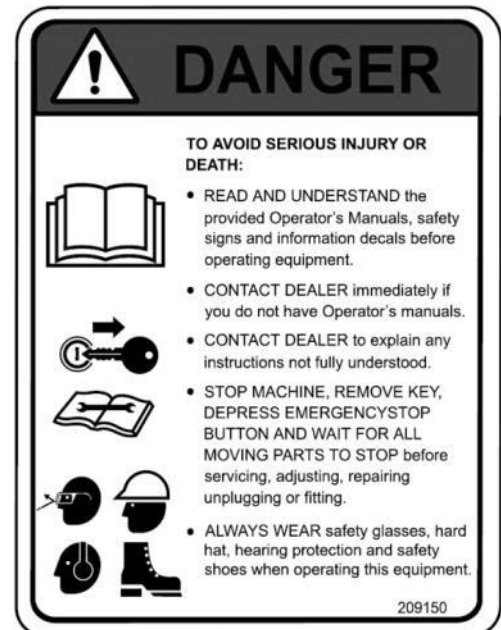



## PARTS ORDERING GUIDE

The following instructions are offered to help eliminate needless delay and error in processing purchase orders for the equipment in this manual.

1. The Parts Section is prepared in logical sequence and grouping of parts that belong to the basic machine featured in this manual. Part Numbers and Descriptions are given to help locate the parts and quantities required.
2. Quantities shown in the parts section are not the total quantity used on the entire machine, they are just the quantities used in the assembly shown on that page.
3. The Purchase Order must indicate the Name and Address of the person or organization ordering the parts, who should be charged, and if possible, the serial number of the machine for which the parts are being ordered.
4. The purchase order must clearly list the quantity of each part, the complete and correct part number, and the basic name of the part.
5. The manufacturer reserves the right to substitute parts where applicable.
6. Some parts may be unlisted items which are special production items not normally stocked and are subject to special handling. Request a quotation for such parts before sending purchase order.
7. The manufacturer reserves the right to change prices without notice.

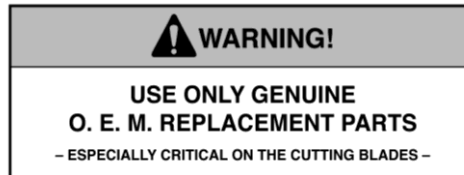



# Table of Contents

<b>SERIAL NUMBER LOCATION.....</b>	<b>III</b>
<b>1 DECK ASSEMBLY .....</b>	<b>2</b>
1.1 BLADE SPINDLE ASSEMBLY – SERIAL # 20111003 - 20111059 .....	2
1.2 BLADE SPINDLE ASSEMBLY – SERIAL # 20111060 – AND UP .....	3
1.3 DECK ASSEMBLY .....	4
1.4 DECK SIDE CHANNEL ASSEMBLY.....	5
1.5 GEARBOX ASSEMBLY .....	6
<b>2 FRAME ASSEMBLY .....</b>	<b>7</b>
2.1 FRAME ASSEMBLY.....	7
2.2 HITCH ASSEMBLY.....	8
2.3 RIGHT WING ASSEMBLY.....	9
2.4 LEFT WING ASSEMBLY .....	10
2.5 REAR LIFT ASSEMBLY.....	11
2.6 LOCK RELEASE ASSEMBLY .....	12
2.7 WHEEL ASSEMBLY .....	13
<b>3 HYDRAULICS .....</b>	<b>14</b>
<b>4 DRIVELINE.....</b>	<b>15</b>
4.1 DRIVELINE LAYOUT.....	15
4.2 INPUT PTO SHAFT .....	16
4.3 INTERMEDIATE PTO SHAFT.....	17
4.4 WING DECK PTO SHAFT .....	18
4.5 REAR DECK PTO SHAFT .....	19
4.6 4-WAY GEARBOX .....	20
4.7 DECK GEARBOX.....	21
<b>5 DECALS .....</b>	<b>22</b>
5.1 SAFETY .....	22
<b>6 NOTES.....</b>	<b>24</b>

# 1 DECK ASSEMBLY

## 1.1 Blade Spindle Assembly – Serial # 20111003 - 20111059

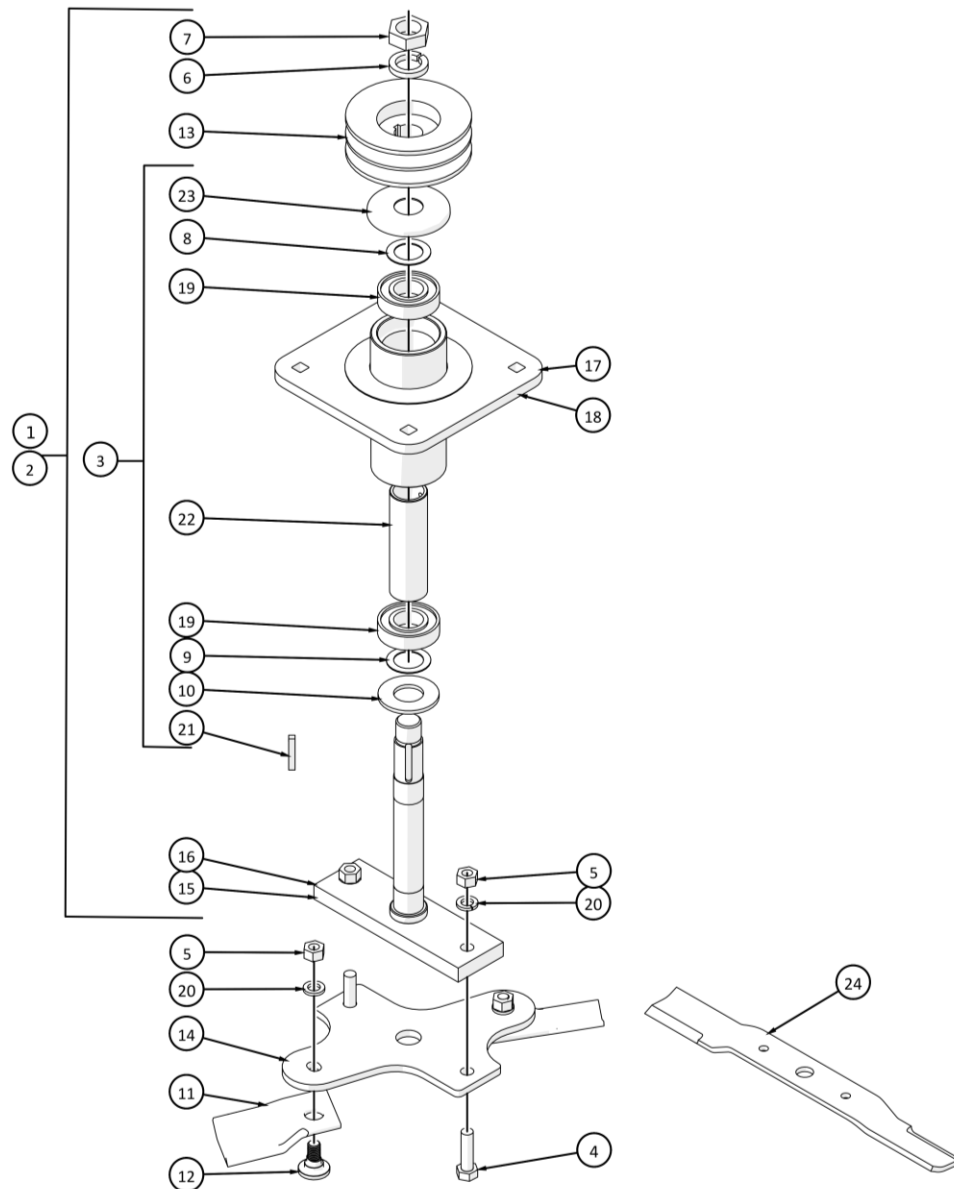

ITEM	PART #	DESCRIPTION	QTY
1	541124	SPINDLE ASSEMBLY COMPLETE - RED	1
2	541124G	SPINDLE ASSEMBLY COMPLETE - GREEN	1
3	524400	BLADE SPINDLE REBUILD KIT	1
4	O.L.	HEX BOLT- 1/2 X 1.75 NC GR5 PL	2
5	O.L.	HEX NUT - 1/2NC GR5 PL	4
6	521002	LOCKWASHER L.H. (3 PCS)	1
7	521003	HEX NUT- L.H.	1
8	-	1.125" SHIM WASHER (9PCS)	1
9	-	SHIM WASHER 1.188" (9PCS)	1
10	-	SPINDLE DIRT SHIELD (3PCS)	1
11	526594	SWING BLADE 50 PCS/KIT	2
12	526866	PRO-EZ II BLADE BOLT KIT- 25 PCS	2
13	527491	PULLEY- 5" 1-1/8" BORE	1

ITEM	PART #	DESCRIPTION	QTY
14	541502	KIT - BLADE BARS FOR 16.75" - 9 PCS	1
15	522566	BLADE SPINDLE - RED	1
16	522566G	BLADE SPINDLE - GREEN	1
17	524220	SPINDLE HOUSING - RED	1
18	524220G	SPINDLE HOUSING - GREEN	1
19	-	BEARING - 6206	2
20	O.L.	LOCK WASHER- 1/2 PL	4
21	O.L.	KEY - 1/4" X 1.50"	1
22	-	BEARING SPACER TUBE	1
23	600625	SHIELD - SPINDLE TOP	1
24	522616	TDRX HIGH LIFT BLADE KIT 9 PCS	1

O.L. - OBTAIN LOCALLY

## 1.2 Blade Spindle Assembly – Serial # 20111060 – and up

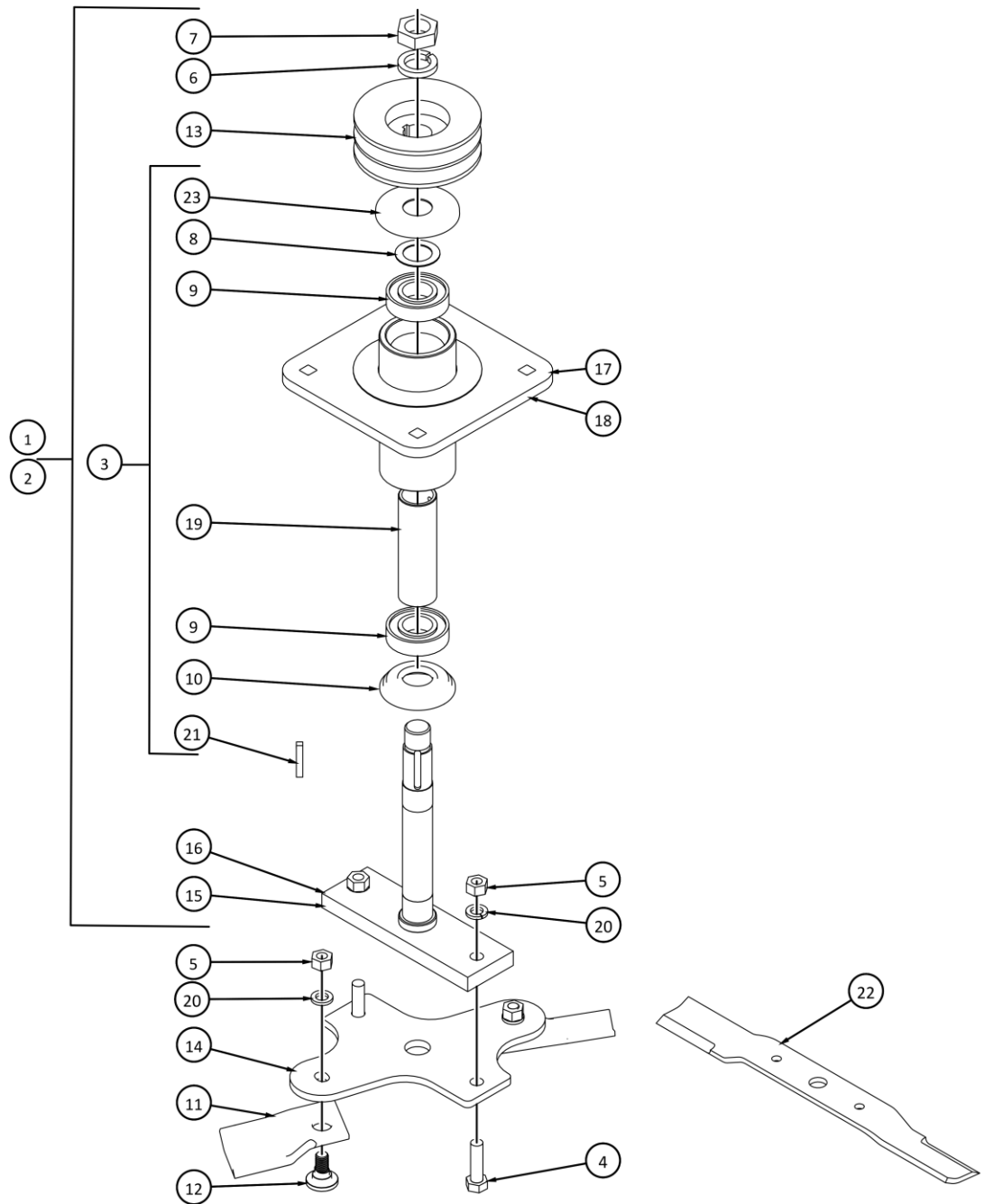

ITEM	PART #	DESCRIPTION	QTY
1	527564	SPINDLE ASSEMBLY COMPLETE - RED	1
2	527564G	SPINDLE ASSEMBLY COMPLETE - GREEN	1
3	527568	BLADE SPINDLE REBUILD KIT	1
4	O.L.	HEX BOLT- 1/2 X 1.75 NC GR5 PL	2
5	O.L.	HEX NUT - 1/2NC GR5 PL	4
6	521002	LOCKWASHER L.H. (3 PCS)	1
7	521003	HEX NUT- L.H.	1
8	521301	1.125" SHIM WASHER (9PCS)	1
9	213051	BEARING - 6206	2
10	527558	HOUSING BOTTOM CAP - 6206	1
11	526594	SWING BLADE 50 PCS/KIT	2
12	526866	PRO-EZ II BLADE BOLT KIT - 25 PCS	2

ITEM	PART #	DESCRIPTION	QTY
13	527491	PULLEY- 5" 1-1/8" BORE	1
14	541502	KIT - BLADE BARS FOR 16.75" - 9 PCS	1
15	522566	BLADE SPINDLE - RED	1
16	522566G	BLADE SPINDLE - GREEN	1
17	527556	SPINDLE HOUSING - RED	1
18	527556G	SPINDLE HOUSING - GREEN	1
19	524222	BEARING SPACER TUBE	1
20	O.L.	LOCK WASHER- 1/2 PL	4
21	O.L.	KEY - 1/4" X 1.50"	1
22	522616	TDRX HIGH LIFT BLADE KIT 9 PCS	1
23	600625	SHIELD - SPINDLE TOP	1

O.L. - OBTAIN LOCALLY

## 1.3 Deck Assembly

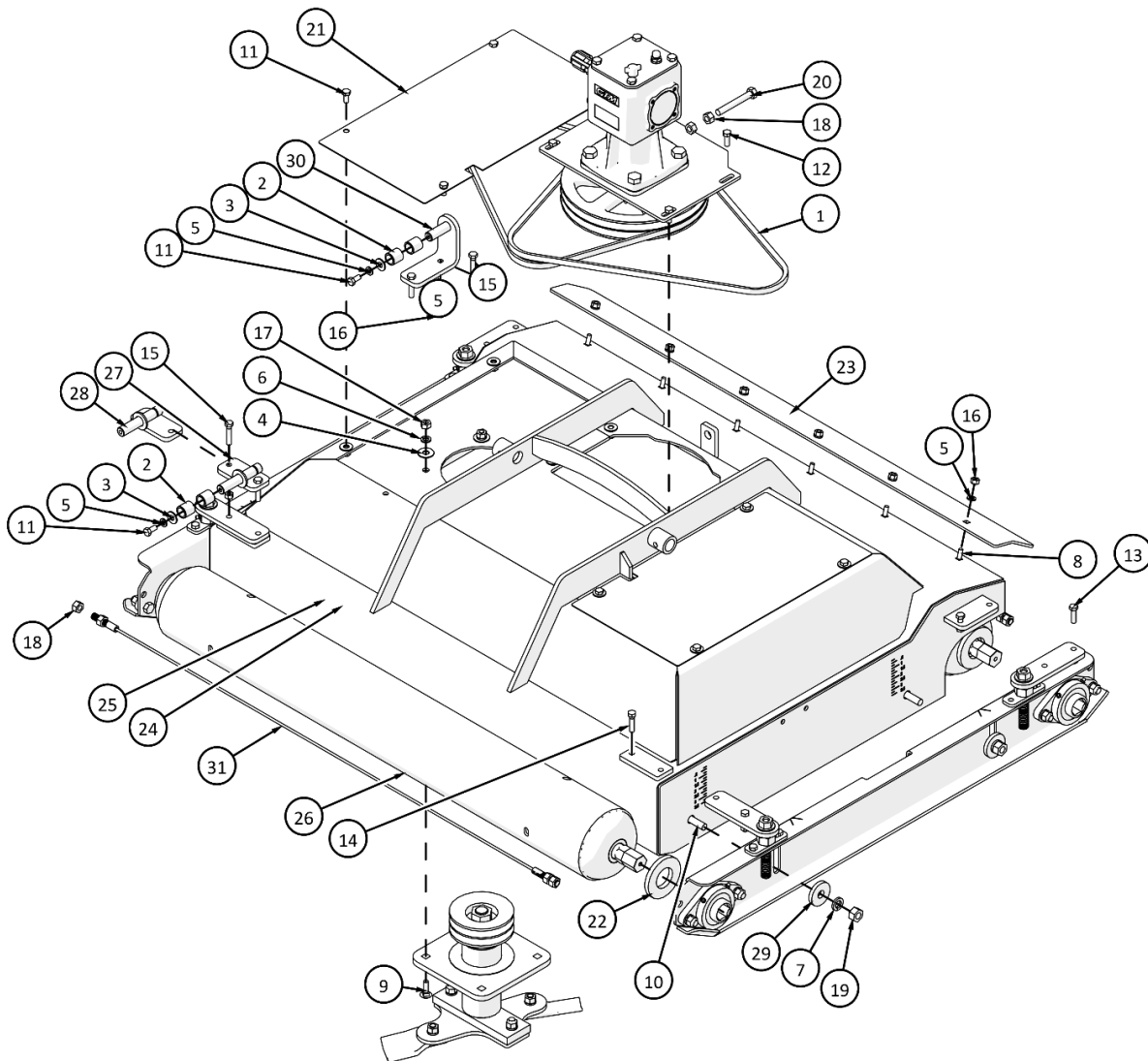

ITEM	Part #	Description	Qty
1	212056	BELT - B61	2
2	213102	BUSHING KIT - 8 PCS - GREY 3/4" ID	4
3	O.L.	FLAT WASHER- 3/8 PL	14
4	O.L.	FLAT WASHER- 7/16 PL	12
5	O.L.	LOCK WASHER- 3/8 PL	16
6	O.L.	LOCK WASHER- 7/16 PL	12
7	O.L.	LOCK WASHER- 5/8 PL	4
8	O.L.	CARR. BOLT- 3/8 X 1 NC GR5 PL	6
9	O.L.	CARR. BOLT- 7/16 X 1.25 NC GR5 PL	12
10	O.L.	CARR. BOLT- 5/8 X 2 NC GR5 PL	4
11	O.L.	HEX BOLT - 3/8 x .75 NC GR5 PL	10
12	O.L.	HEX BOLT- 3/8 X 1 NC GR5 PL	4
13	O.L.	HEX BOLT - 3/8 x 1.25 NC GR5 PL	2
14	O.L.	HEX BOLT- 3/8 X 1.5 NC GR5 PL	2
15	O.L.	HEX BOLT- 3/8 X 1.75 NC GR5 PL	4
16	O.L.	HEX NUT - 3/8NC GR5 PL	14

ITEM	Part #	Description	Qty
17	O.L.	HEX NUT - 7/16NC GR5 PL	12
18		HEX NUT - 1/2NC GR5 PL	10
19	O.L.	HEX NUT - 5/8NC GR5 PL	4
20	O.L.	HEX BOLT- 1/2 X 3.5 NC GR5 PL TAP BOLT	1
21	541043	DECK SHIELD - SIDE	2
22	541500	KIT ROLLER THRUST PAD - 4 PCS	4
23	541335	GRASS DEFLECTOR - DECK	1
24	541006	MOWER DECK - RED	1
25	541006G	MOWER DECK GREEN	1
26	541018	DECK ROLLER - TDR10	2
27	541142	STANDOFF MOUNT - FRONT LEFT	1
28	541146	STANDOFF MOUNT - FRONT RIGHT	1
29	526148	TDR CLAMP WASHER KIT (4PCS)	1
30	541120	REAR STANDOFF	1
31	541156	ROLLER WIPER CABLE - TDR-X	2

O.L. - OBTAIN LOCALLY

# 1.4 Deck Side Channel Assembly

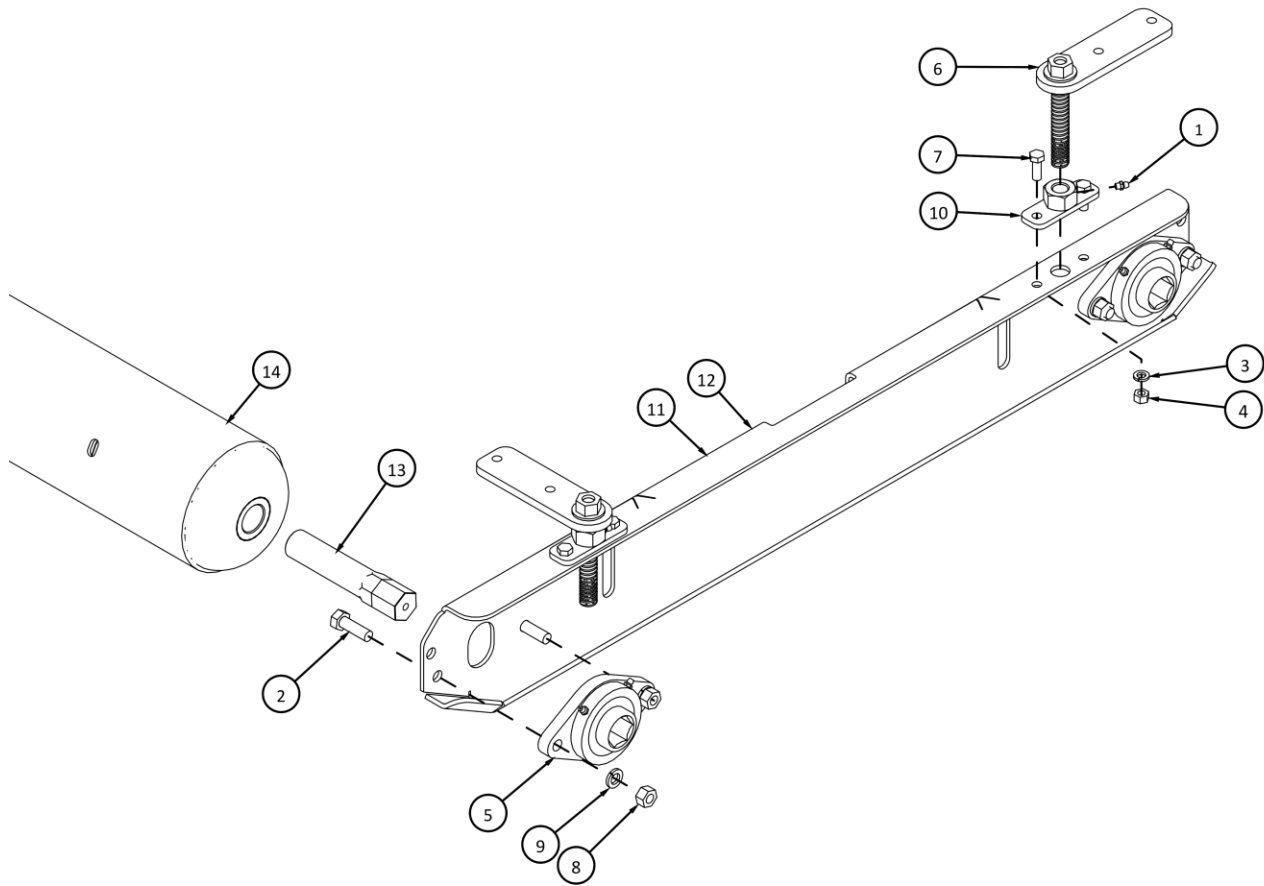

ITEM	PART #	DESCRIPTION	QTY
1	O.L.	GREASE FITTING 1/4 - 28	2
2	O.L.	HEX BOLT- 1/2 X 1.5 NC GR5 PL	4
3	O.L.	LOCK WASHER- 3/8 PL	4
4	O.L.	HEX NUT - 3/8NC GR5 PL	4
5	213025	FLANGE BEARING - 2 BOLT HEX GREASABLE	2
6	541144	HEIGHT ADJ. ROD	2
7	O.L.	HEX BOLT- 3/8 X 1 NC GR5 PL	4
8	O.L.	HEX NUT - 1/2NC GR5 PL	4

ITEM	PART #	DESCRIPTION	QTY
9	O.L.	LOCK WASHER- 1/2 PL	4
10	541012	HEIGHT ADJ MOUNT	2
11	541016	DECK SIDE CHANNEL - RED	1
12	541016G	DECK SIDE CHANNEL - GREEN	1
13	541055	ROLLER SHAFT - HEX	1
14	541018	DECK ROLLER WITH SHAFTS	1

O.L. - OBTAIN LOCALLY

# 1.5 Gearbox Assembly

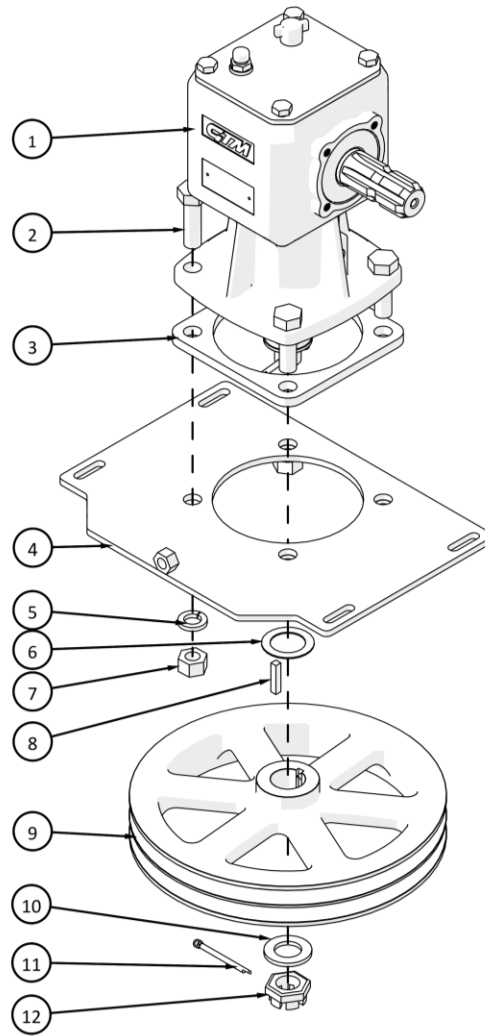

ITEM	Part #	Description	Qty
1	215116	GEAR BOX DECK	1
2	O.L.	HEX BOLT- 5/8 X 2 NC GR5 PL	4
3	528657	GEAR BOX SPACER PLATE	1
4	541084	GEAR BOX MOUNT	1
5	O.L.	LOCK WASHER- 5/8 PL	4
6	521004	SHIM WASHER - 1.25 (9 PCS)	1
7	O.L.	HEX NUT - 5/8NC GR5 PL	4

ITEM	Part #	Description	Qty
8	O.L.	KEY - 1/4" X 1.25"	1
9	212021	PULLEY - 11-1/4"	1
10	521129	WASHER - 25 X 44 X 4	1
11	O.L.	3/16 X 1-1/2" COTTER PIN	1
12	521130	CASTLE NUT - M24	1

O.L. - OBTAIN LOCALLY



# 2 FRAME ASSEMBLY

## 2.1 Frame Assembly

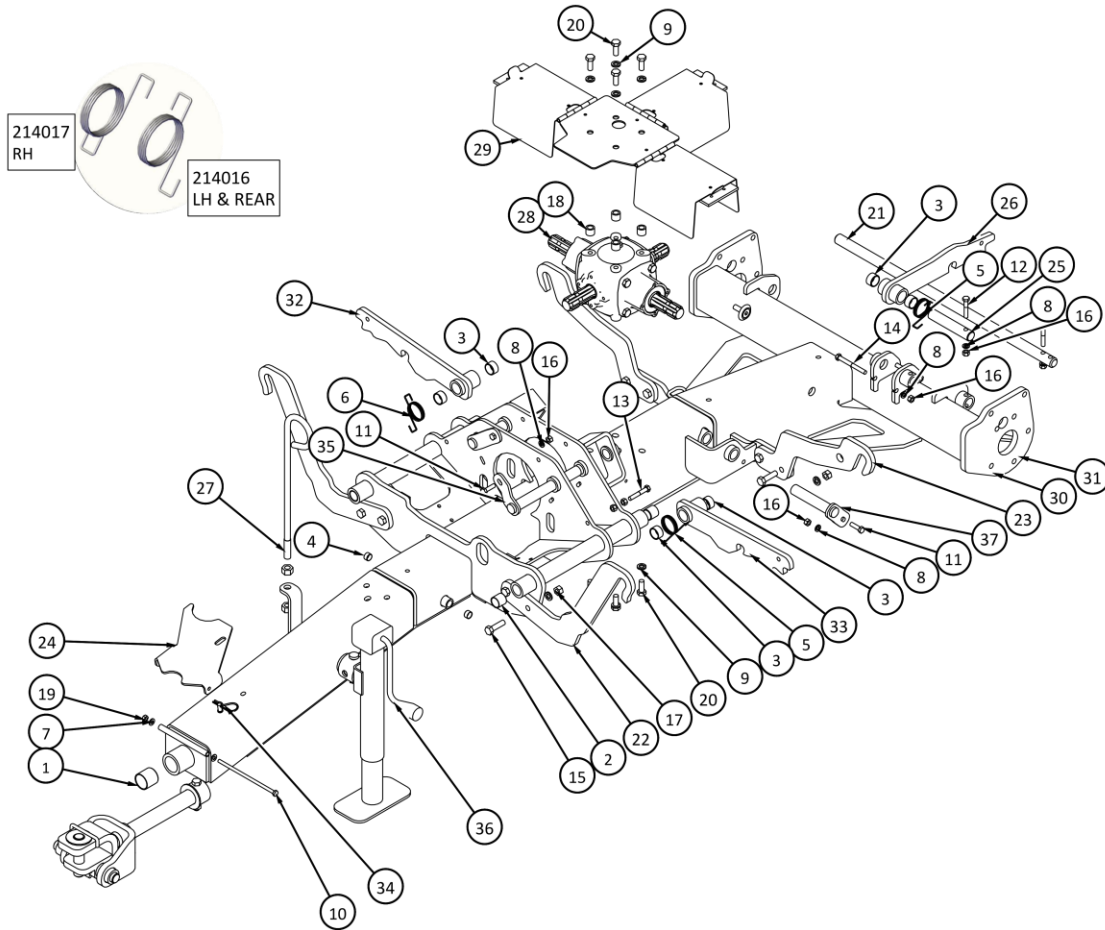

ITEM	PART #	DESCRIPTION	QTY
1	213110	BUSHING KIT -2 PCS - BEIGE- 1.5"ID X 1.5"	2
2	213108	BUSHING KIT - 4 PCS - BEIGE- 1"ID X 1"	4
3	213112	BUSHING KIT -6 PCS-GREY- 26MMID X 16MM	6
4	213114	BUSHING KIT -2 PCS-YELLOW- 16MMID X 10MM	2
5	214016	SPRING - DECK ARM LOCK - LH	2
6	214017	SPRING - DECK ARM LOCK - RH	1
7	O.L.	FLAT WASHER- 5/16 PL	2
8	O.L.	LOCK WASHER- 3/8 PL	8
9	O.L.	LOCK WASHER- 1/2 PL	16
10	O.L.	HEX BOLT- 5/16 X 7.5 NC GR5 PL	1
11	O.L.	HEX BOLT - 3/8 x 1.25 NC GR5 PL	3
12	O.L.	HEX BOLT- 3/8 X 2 NC GR5 PL	3
13	O.L.	HEX BOLT- 3/8 X 2.25 NC GR5 PL	2
14	O.L.	HEX BOLT- 3/8 X 3 NC GR5 PL	2
15	O.L.	HEX BOLT- 1/2 X 1.75 NC GR5 PL	8
16	O.L.	HEX NUT - 3/8NC GR5 PL	12
17	O.L.	HEX NUT - 1/2NC GR5 PL	8
18	521197	GEAR BOX COVER SPACER	4
19	O.L.	HEX LOCK NUT - 5/16 NC GRA CTR	1

ITEM	PART #	DESCRIPTION	QTY
20	O.L.	HEX BOLT - M12 X 30GR 8.8	8
21	541405	PIN - REAR LIFT	1
22	541263	STANDOFF - FRONT	2
23	541265	STANDOFF REAR	2
24	541327	PTO SUPPORT PLATE	1
25	541339	PIN - REAR LOCK	1
26	541214	REAR LOCK WITH BUSHINGS	1
27	522413	HOSE GUIDE - CW HARDWARE	1
28	521497B	GEAR BOX - 4 SHAFT - BLACK	1
29	522463	4-WAY GEARBOX COVER	1
30	541036	MAIN FRAME - TDRX - RED	1
31	541036G	MAIN FRAME - TDRX - GREEN	1
32	541218	WING LOCK R.H. WITH BUSHINGS	1
33	541216	WING LOCK L.H. WITH BUSHINGS	1
34	O.L.	HAIR PIN - 1/8 x 2 9/16	1
35	541056	PIN - CYLINDER	2
36	219005	IMPLEMENT JACK	1
37	607398	PIN - CYLINDER	1

O.L. - OBTAIN LOCALLY

## 2.2 Hitch Assembly

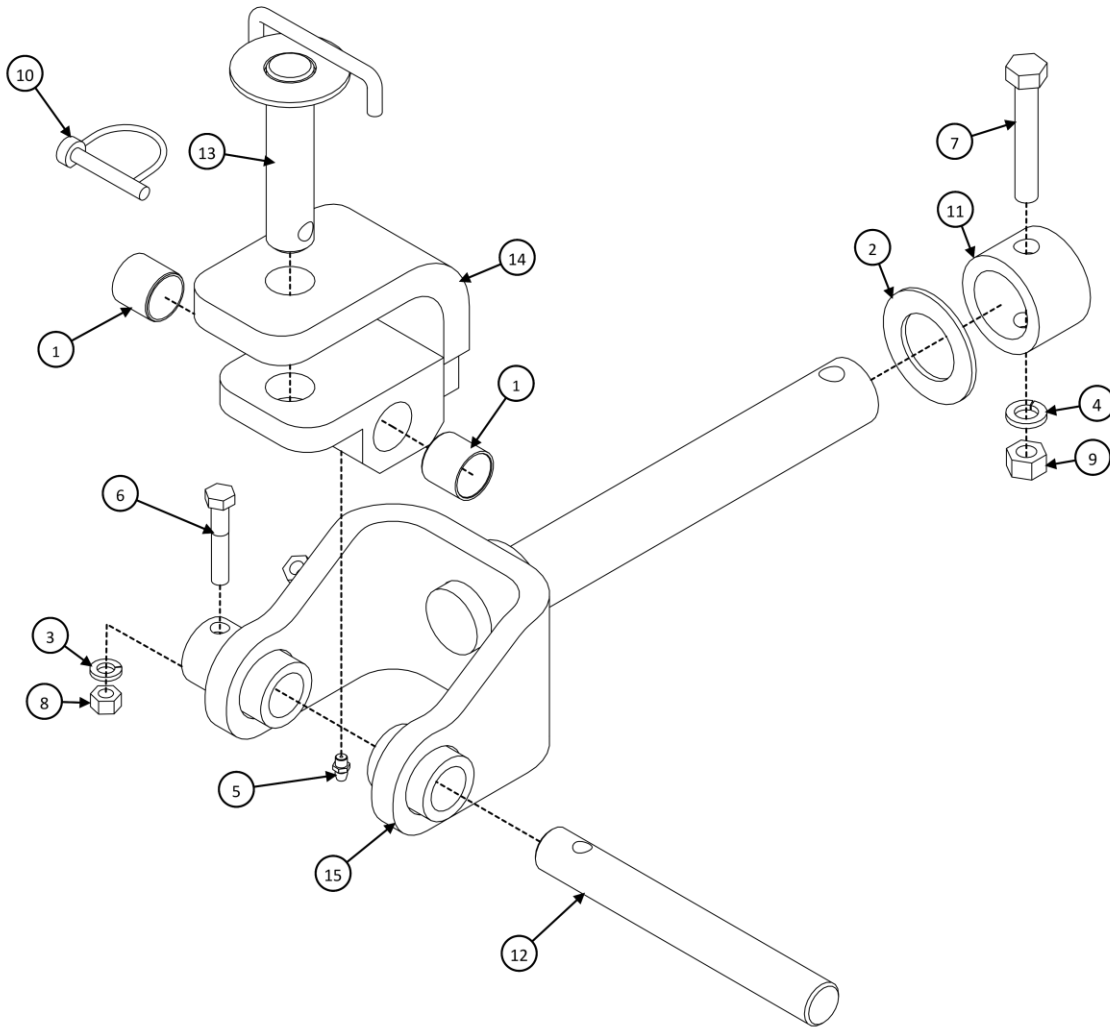

ITEM	PART #	DESCRIPTION	QTY
1	213100	BUSHING KIT - 2 PCS - GREY 1"	2
2	213081	THRUST WASHER - 1.5"	1
3	O.L.	LOCK WASHER- 3/8 PL	1
4	O.L.	LOCK WASHER- 1/2 PL	1
5	O.L.	GREASE FITTING 1/4 - 28	1
6	O.L.	HEX BOLT- 3/8 X 2 NC GR5 PL	1
7	O.L.	HEX BOLT- 1/2 X 3 NC GR5 PL	1
8	O.L.	HEX NUT - 3/8NC GR5 PL	1

ITEM	PART #	DESCRIPTION	QTY
9	O.L.	HEX NUT - 1/2NC GR5 PL	1
10	302902	LYNCH PIN - 5/16"	1
11	541241	HITCH COLLAR	1
12	541251	HITCH PIVOT PIN	1
13	541082	HITCH PIN	1
14	541172	MAIN HITCH	1
15	541050	HITCH RECEIVER	1

O.L. - OBTAIN LOCALLY

## 2.3 Right Wing Assembly

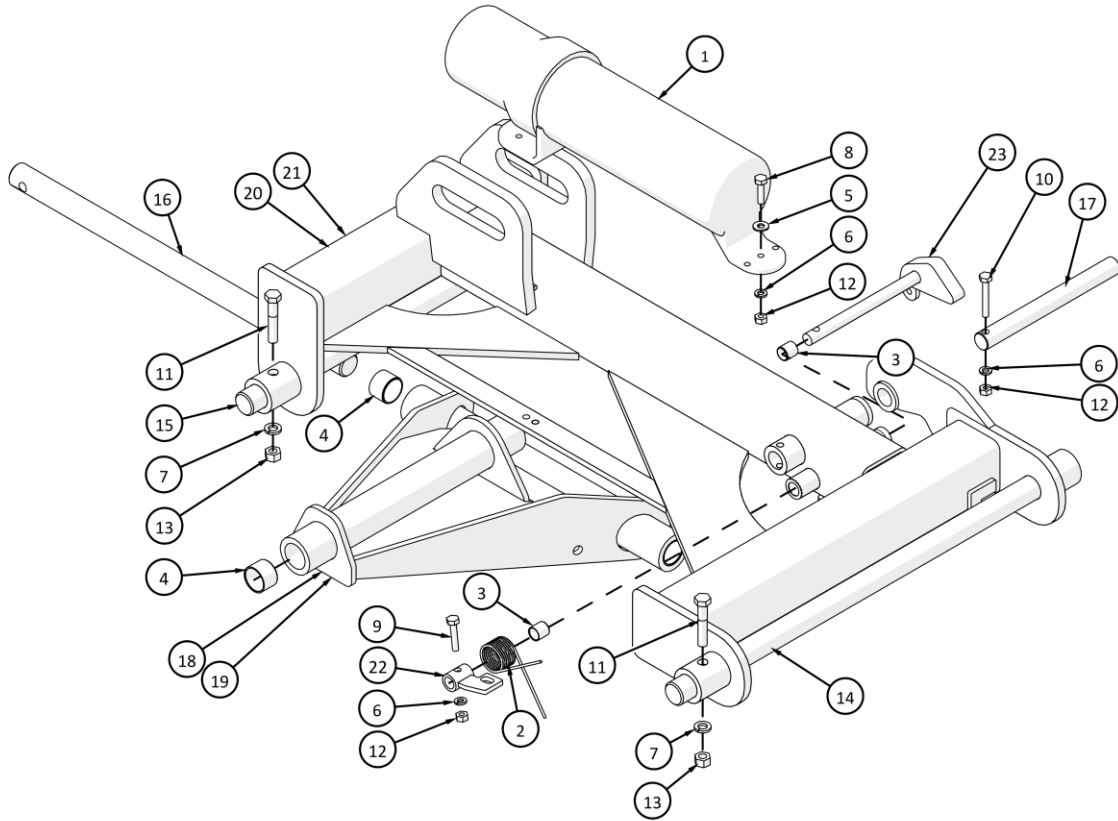

ITEM	Part #	Description	Qty
1	120519	MANUAL HOLDER TUBE	1
2	214020	SPRING - LOCK RELEASE RH	1
3	213104	BUSHING KIT - 6 PCS - YELLOW 13MM ID	2
4	213106	BUSHING KIT - 4 PCS - RED- 1"ID X 3/4"	4
5	O.L.	FLAT WASHER- 1/4 PL	2
6	O.L.	LOCK WASHER - 1/4 PL	4
7	O.L.	LOCK WASHER- 3/8 PL	2
8	O.L.	HEX BOLT - 1/4 x 1 NC GR5 PL	2
9	O.L.	HEX BOLT - 1/4 x 1.25 NC GR5 PL	1
10	O.L.	HEX BOLT - 1/4 x 1.75 NC GR5 PL	1
11	O.L.	HEX BOLT- 3/8 X 2 NC GR5 PL	2
12	O.L.	HEX NUT - 1/4NC GR5 PL	4

ITEM	Part #	Description	Qty
13	O.L.	HEX NUT - 3/8NC GR5 PL	2
14	541249	PIN - WING	1
15	541253	PIN - SWIVEL	1
16	541255	PIN - DECK LIFT	1
17	541423	PIN - WING LOCK	1
18	541022	DECK SWIVEL - WING - RED	1
19	541022G	DECK SWIVEL - WING - GREEN	1
20	541028	WING- RH - RED	1
21	541028G	WING- RH- GREEN	1
22	541076	LOCK RELEASE RETURN	1
23	541114	LOCK RELEASE RH WING	1

O.L. - OBTAIN LOCALLY

## 2.4 Left Wing Assembly

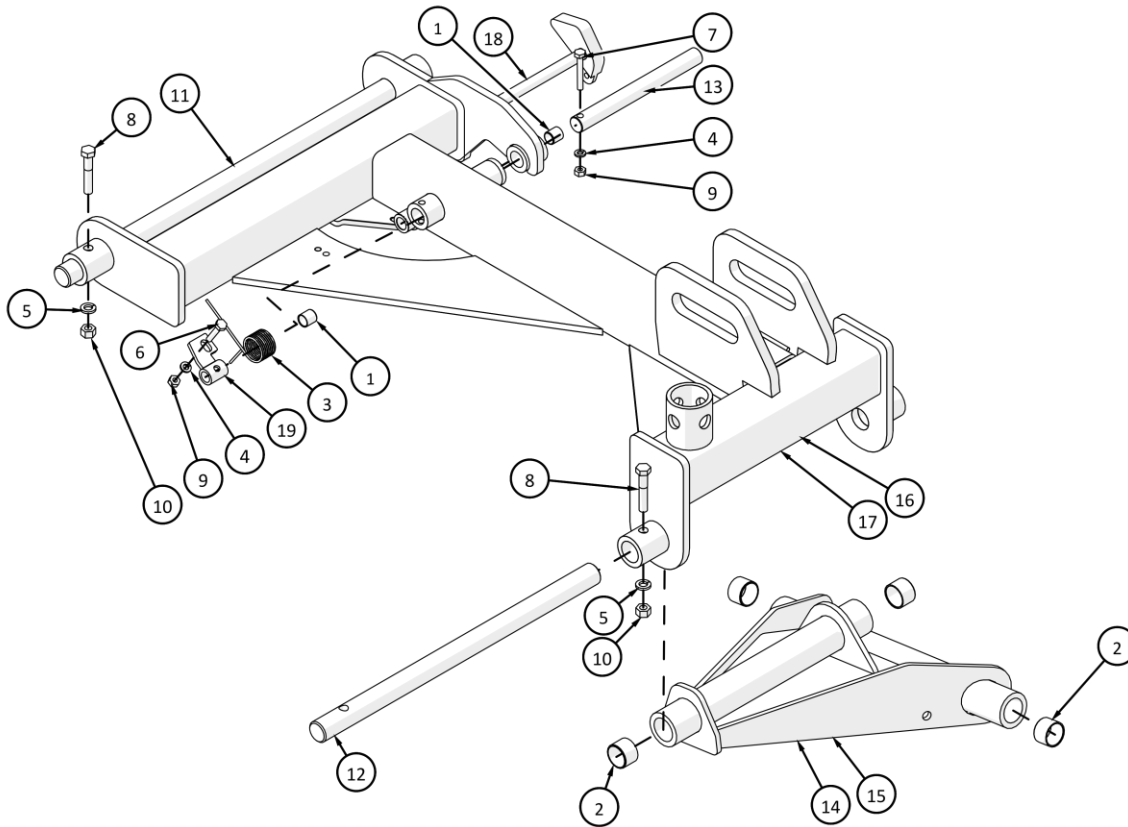

ITEM	PART #	DESCRIPTION	QTY
1	213104	BUSHING KIT - 6 PCS - YELLOW 13MM ID	2
2	213106	BUSHING KIT - 4 PCS - RED- 1"ID X 3/4"	4
3	214019	SPRING - LOCK RELEASE LH	1
4	O.L.	LOCK WASHER - 1/4 PL	2
5	O.L.	LOCK WASHER- 3/8 PL	2
6	O.L.	HEX BOLT - 1/4 x 1.25 NC GR5 PL	1
7	O.L.	HEX BOLT - 1/4 x 1.75 NC GR5 PL	1
8	O.L.	HEX BOLT- 3/8 X 2 NC GR5 PL	2
9	O.L.	HEX NUT - 1/4NC GR5 PL	2
10	O.L.	HEX NUT - 3/8NC GR5 PL	2

ITEM	PART #	DESCRIPTION	QTY
11	541249	PIN - WING	1
12	541253	PIN - SWIVEL	1
13	541423	PIN - WING LOCK	1
14	541022	DECK SWIVEL - WING - RED	1
15	541022G	DECK SWIVEL - WING - GREEN	1
16	541026	WING - LH - RED	1
17	541026G	WING - LH - GREEN	1
18	541068	LOCK RELEASE LH WING	1
19	541076	LOCK RELEASE RETURN	1

O.L. - OBTAIN LOCALLY

## 2.5 Rear Lift Assembly

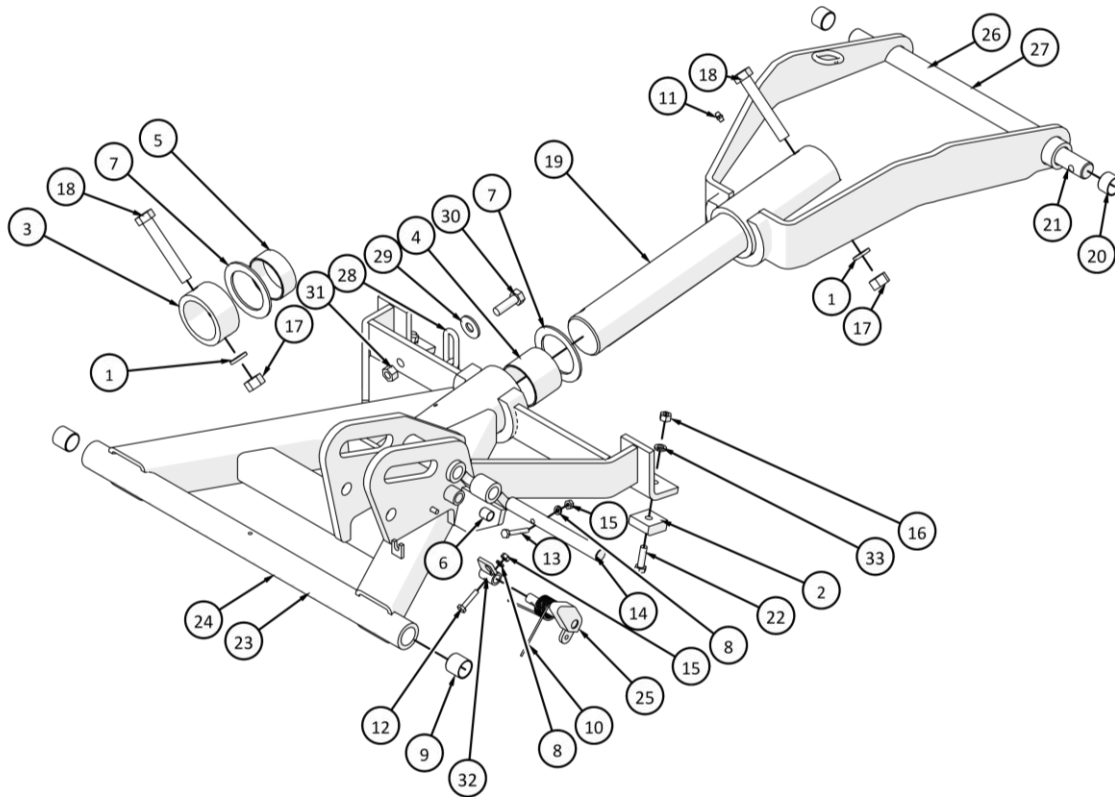

ITEM	PART #	Description	QTY
1	O.L.	LOCK WASHER- 5/8 PL	2
2	541504	BUMPER KIT (2 PCS)	1
3	541245	REAR LIFT COLLAR	1
4	213077	BUSHING - 2.5" ID X 2"	1
5	213078	BUSHING - 2.5" ID X 1"	1
6	213104	BUSHING KIT - 6 PCS - YELLOW 13MM ID	2
7	213120	WASHER KIT -2 PCS-GREY- 2.5"ID	2
8	O.L.	LOCK WASHER- 1/4 PL	2
9	213100	BUSHING KIT - 2 PCS - GREY 1"	2
10	214020	SPRING - LOCK RELEASE RH	1
11	O.L.	GREASE FITTING 1/4 - 28	1
12	O.L.	HEX BOLT - 1/4 x 1.25 NC GR5 PL	1
13	O.L.	HEX BOLT - 1/4 x 1.75 NC GR5 PL	1
14	541429	PIN - REAR LOCK	1
15	O.L.	HEX NUT - 1/4NC GR5 PL	2
16	O.L.	HEX NUT - 3/8NC GR5 PL	2
17	O.L.	HEX NUT - 5/8NC GR5 PL	2

ITEM	PART #	Description	QTY
18	O.L.	HEX BOLT- 5/8 X 4 NC GR8 PL	2
19	541259	PIN - REAR SWIVEL	1
20	213106	BUSHING KIT - 4 PCS - RED- 1"ID X 3/4"	2
21	541255	PIN - DECK LIFT	1
22	O.L.	HEX BOLT - 3/8 x 1.25 NC GR5 PL	2
23	541148	REAR LIFT - RED	1
24	541148G	REAR LIFT - GREEN	1
25	541154	LOCK RELEASE REAR	1
26	541024	REAR DECK SWIVEL - RED	1
27	541024G	REAR DECK SWIVEL - GREEN	1
28	526972	DECK STOP CHAIN	2
29	O.L.	FLAT WASHER - 1/2 USS PL	2
30	O.L.	HEX BOLT- 1/2 X 1.5 NC GR5 PL	2
31	O.L.	HEX NUT - 1/2 NC GR5 PL	2
32	541076	LOCK RELEASE RETURN	1
33	O.L.	LOCK WASHER- 3/8 PL	2

O.L. - OBTAIN LOCALLY

## 2.6 Lock Release Assembly

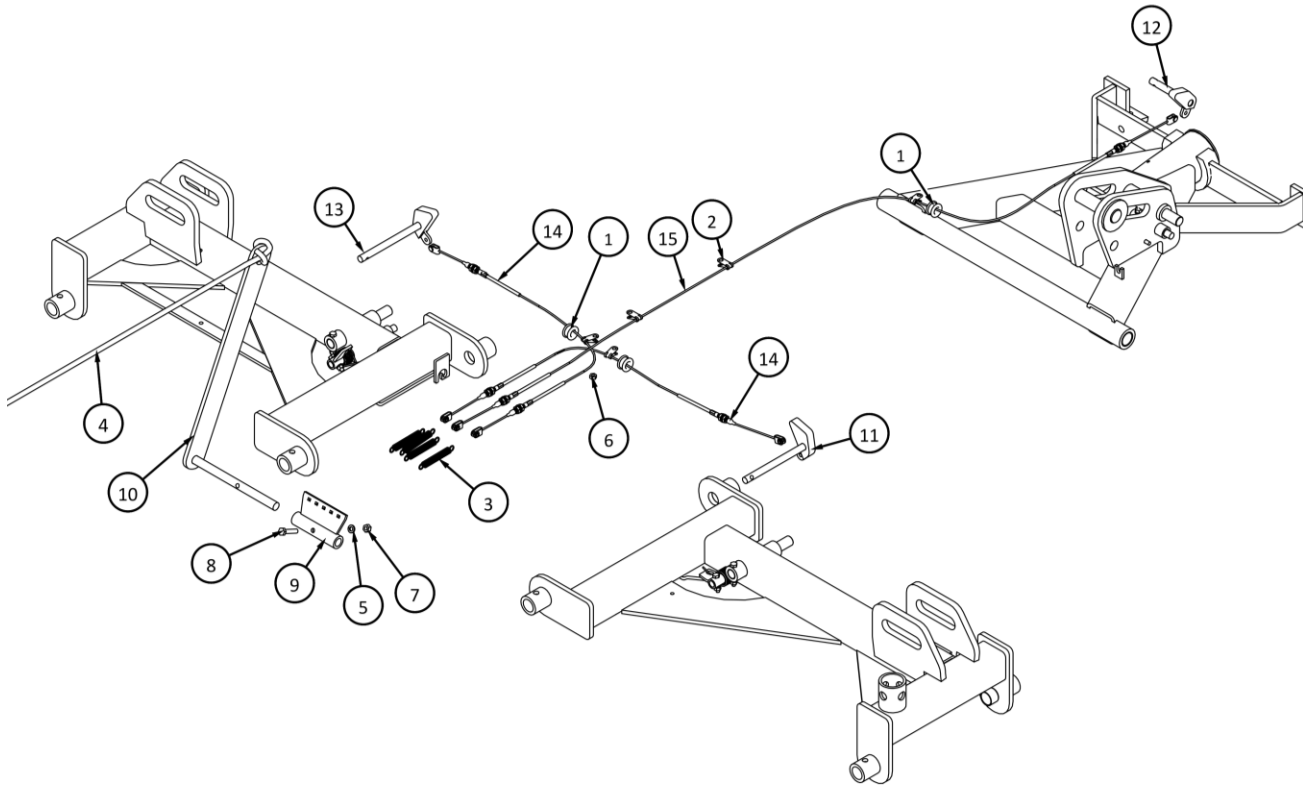

ITEM	PART #	DESCRIPTION	QTY
1	213116	GROMMET KIT -3 PCS- 9/16" X 3/8"	3
2	213118	CABLE CLAMP KIT -5 PCS- 3/16" DIA	5
3	214022	KIT- LOCK CABLE SPRINGS, 4 PCS	4
4	521331	PULL ROPE - 10'	1
5	O.L.	LOCK WASHER- 5/16 PL	1
6	O.L.	HEX LOCK NUT - 1/4NC GR5 PL	1
7	O.L.	HEX NUT - 5/16NC GR5 PL	1
8	O.L.	HEX BOLT- 5/16 X 1.5 NC GR5 PL	1

ITEM	PART #	DESCRIPTION	QTY
9	541064	LOCK RELEASE PIVOT	1
10	541066	LOCK RELEASE HANDLE	1
11	541068	LOCK RELEASE LH WING	1
12	541154	LOCK RELEASE REAR	1
13	541114	LOCK RELEASE RH WING	1
14	541130	LOCK RELEASE CABLE - WING - 35.0'	2
15	541132	LOCK RELEASE CABLE - REAR- 70"	1

O.L. - OBTAIN LOCALLY

## 2.7 Wheel Assembly

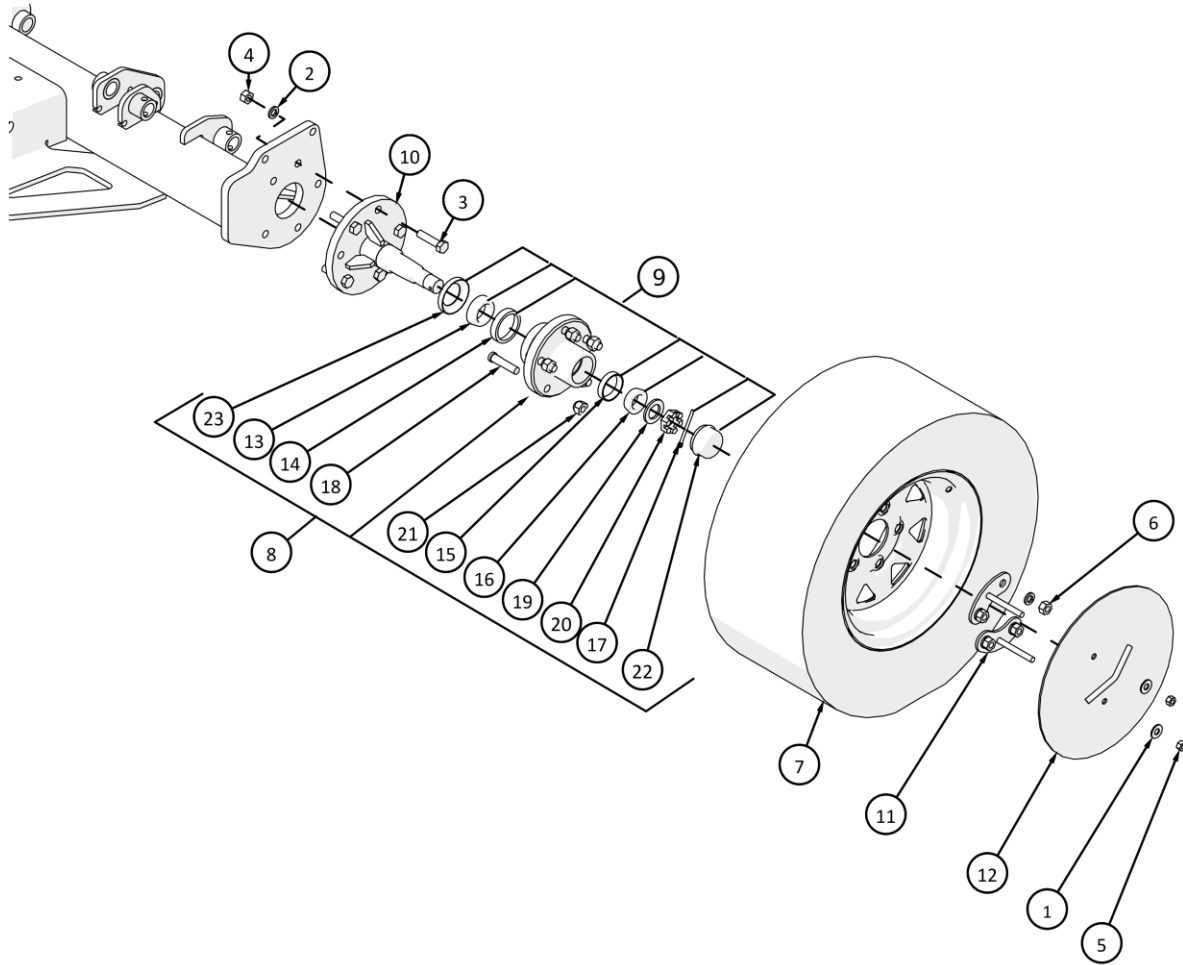

ITEM	Part #	Description	Qty
1	O.L.	FLAT WASHER- 3/8 PL	2
2	O.L.	LOCK WASHER- 1/2 PL	9
3	O.L.	HEX BOLT- 1/2 X 2 NC GR5 PL	5
4	O.L.	HEX NUT - 1/2NC GR5 PL	5
5	O.L.	HEX LOCK NUT - 3/8 NC GR5 PL	2
6	O.L.	HEX NUT - 1/2NF GR8 PL	4
7	230087	WHEEL ASSY TDR-X	1
8	521328	HUB ASSEMBLY W/ALL PARTS	1
9	230028	WHEEL REBUILD KIT	1
10	541040	REPLACEABLE AXLE	1
11	541078	WHEEL DISC MOUNT	2
12	541080	HUB CAP - TDRX	1

ITEM	Part #	Description	Qty
13	-	BEARING - CONE	1
14	-	BEARING CUP - INNER	1
15	-	BEARING CUP - OUTER	1
16	-	BEARING - CONE	1
17	O.L.	3/16 X 1-1/2" COTTER PIN	1
18	521755	PRESS IN WHEEL STUD (5 PCS)	1
19	521746	WASHER (2 PCS)	1
20	521747	HEX NUT - CASTELATED (2 PCS)	1
21	521327	WHEEL NUT KIT (5 PCS)	1
22	521748	DUST CAP	1
23	521741	GREASE SEAL	1

O.L. - OBTAIN LOCALLY



### 3 HYDRAULICS

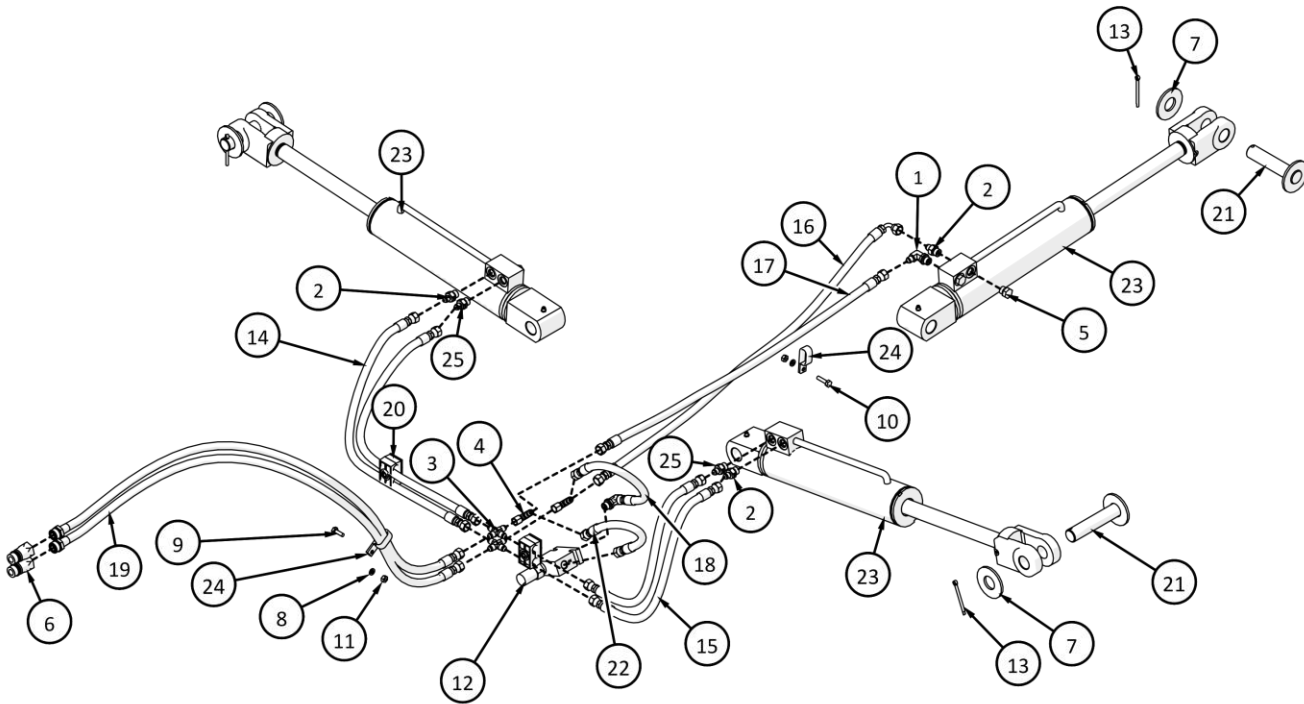

ITEM	PART #	DESCRIPTION	QTY
1	221142	ELBOW -6 ORBM X -4 JICM 90DEG	1
2	221150	ADAPTER - JIC#4M -ORB#6M-REST-0.032	3
3	221152	CROSS- #6JIC MALE	2
4	221153	TEE- #6JIC M-F-M	2
5	221154	PLUG - #6 ORB MALE	6
6	222006	HOSE END KIT - (2 PCS)	2
7	O.L.	FLAT WASHER- 1 PL	3
8	O.L.	LOCK WASHER - 1/4 PL	2
9	O.L.	HEX BOLT - 1/4 x .75 NC GR5 PL	1
10	O.L.	HEX BOLT - 1/4 x 1 NC GR5 PL	1
11	O.L.	HEX NUT - 1/4NC GR5 PL	2
12	528822	RELIEF VALVE	1
13	O.L.	3/16 X 1-1/2" COTTER PIN	3

ITEM	PART #	DESCRIPTION	QTY
14	221155	HYD HOSE - RIGHT WING CYL	2
15	221156	HYD. HOSE - LEFT WING CYL	2
16	221157	HYD HOSE - REAR CYL 90DEG	1
17	221158	HYD HOSE - REAR CYL	1
18	221159	HYD HOSE 90 deg- RELIEF VALVE	1
19	221160	HYDRAULIC HOSE 1/4" - 115"	2
20	229019	DOUBLE HOSE CLAMP	2
21	541116	ROD END CYL PIN - TDR-X	3
22	221161	HYD HOSE - RELIEF VALVE	1
23	522072	HYDRAULIC CYL.-2.5" X 10"	3
24	229008	5/8 DOUBLE TUBE CLAMP	2
25	221150	ADAPTER - JIC#4M -ORB#6M	2

O.L. - OBTAIN LOCALLY



# 4 DRIVELINE

## 4.1 Driveline Layout

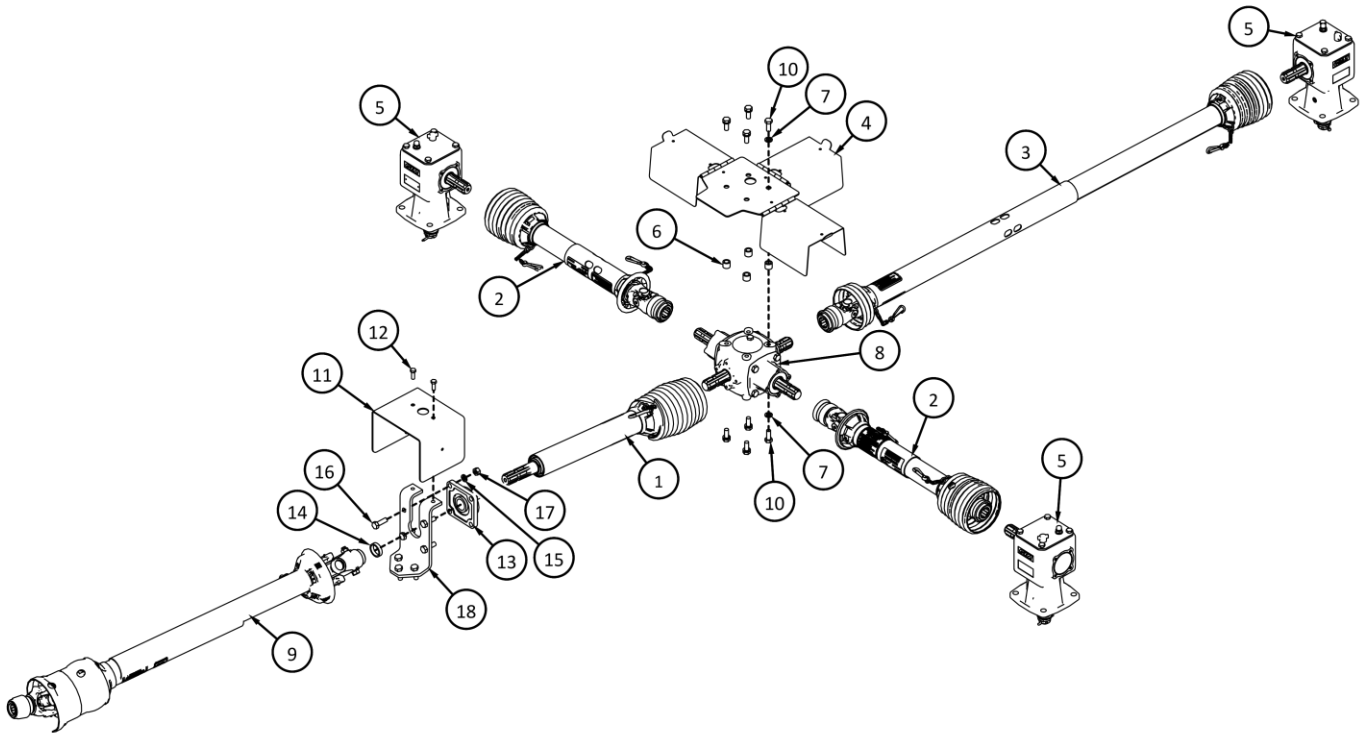

ITEM	PART #	DESCRIPTION	QTY
1	210210	INTERMEDIATE PTO-w/OVERRUNNING	1
2	210306	WING PTO SHAFT - TDR-X, 6 SERIES	2
3	210316	REAR PTO SHAFT - TDR-X, 6 SERIES	1
4	522463	4-WAY G-BOX SHIELD	1
5	215116	GEAR BOX RG-30	3
6	521197	GEAR BOX COVER SPACER	4
7	O.L.	LOCK WASHER- 1/2 PL	4
8	521497B	GEAR BOX - 4 SHAFT - BLACK	1
9	210320	INPUT PTO	1
10	521764	HEX BOLT-M12X30 & L.W (16 PCS)	8

ITEM	PART #	DESCRIPTION	QTY
11	541239	INTERMEDIATE SHIELD	1
12	O.L.	HEX BOLT- 3/8 X 1 NC GR5 PL	2
13	521323	4 BOLT FLANGE BEARING - 1-3/8"	1
14	526013	INPUT PTO SPACER 0.400"	1
15	O.L.	LOCK WASHER- 1/2 PL	3
16	O.L.	HEX BOLT- 1/2 X 1.5 NC GR5 PL	4
17	O.L.	HEX NUT - 1/2NC GR5 PL	3
18	541042	PTO MOUNT PLATE	1

O.L. - OBTAIN LOCALLY

## 4.2 Input PTO Shaft

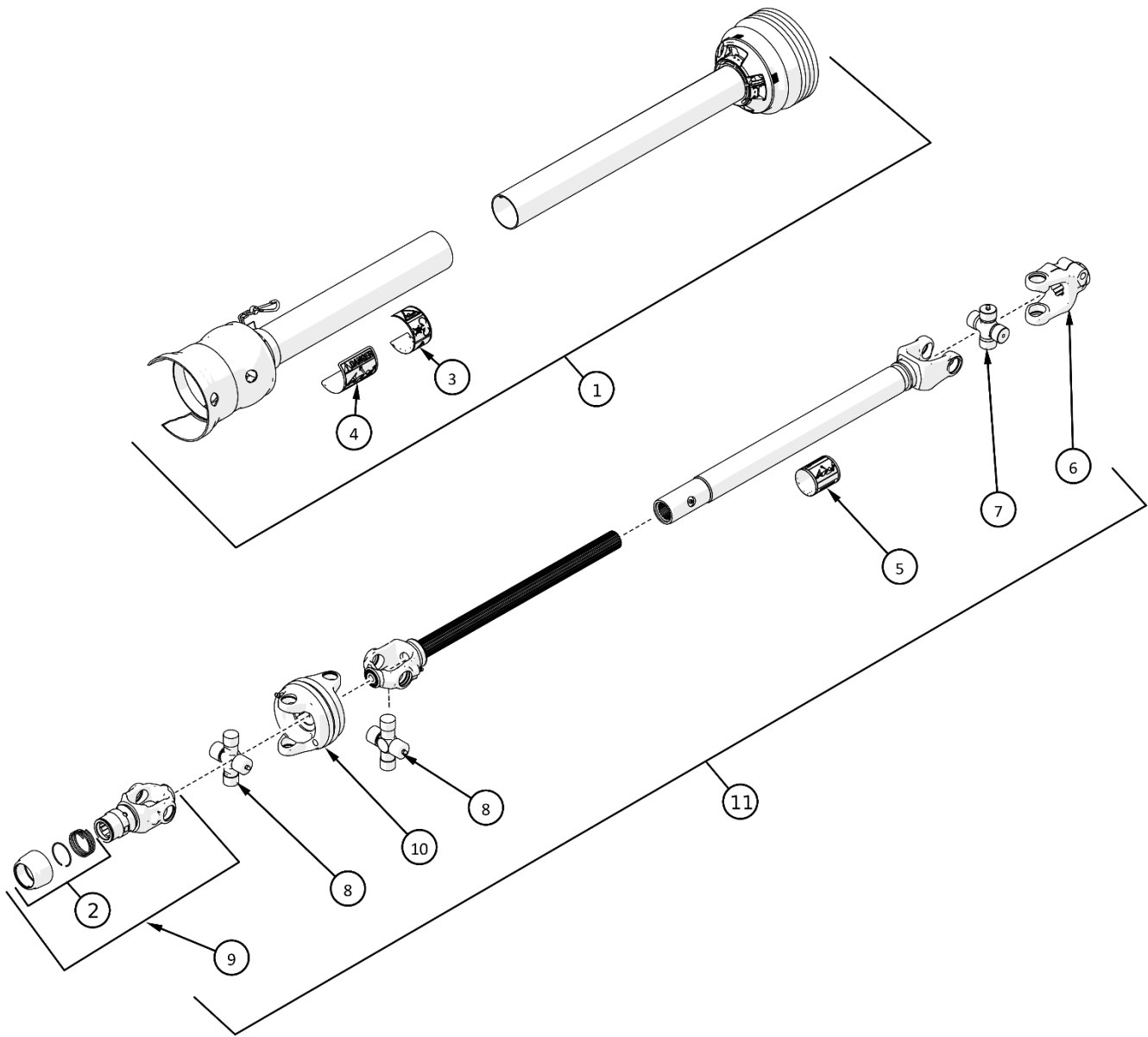

ITEM	PART #	DESCRIPTION	QTY
1	210321	COMPLETE GUARD SET	1
2	210179	SLIDE LOCK REPAIR KIT(44E)	1
3	210238	CE WARNING DECAL	1
4	210237	SAFETY SIGN - OUTER GUARD	1
5	210239	SAFETY SIGN - INNER GUARD	1
6	210235	35 SERIES CLAMP YOKE	1
7	210234	35E2BL CROSS KIT	1
8	210284	CAT 4 80 EBL CROSS & BRG KIT	2
9	210283	AUTO LOK YOKE ASSEMBLY	1
10	210281	CENTER HOUSING	1
11	210320	COMPLETE INPUT PTO WITH GUARDS	1

### 4.3 Intermediate PTO Shaft

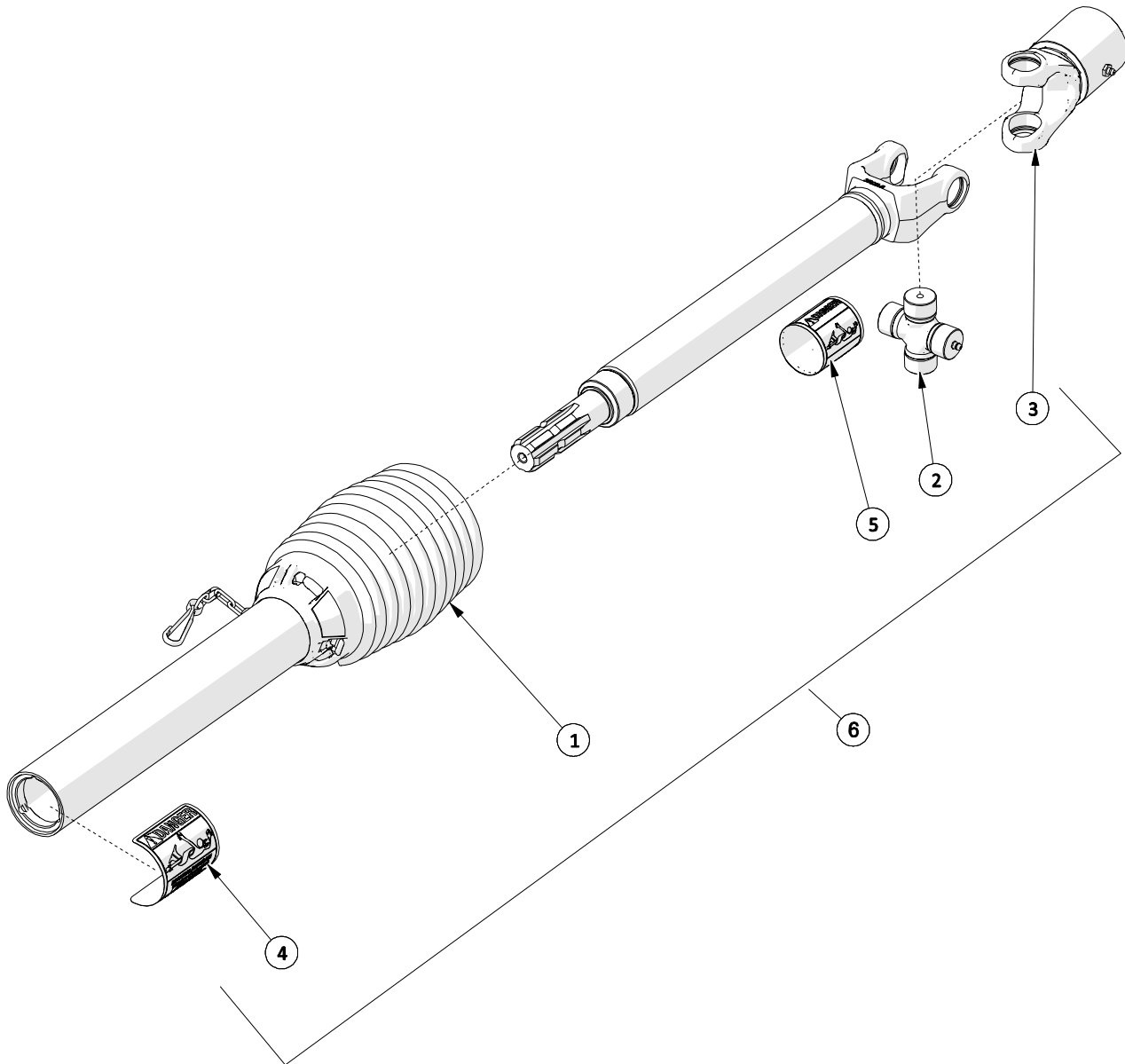

ITEM	PART #	Description	QTY
1	210211	PTO GUARD	1
2	210234	35E2BL CROSS & BEARING KIT	1
3	210212	OVERRUNNING CLUTCH ASSEMBLY	1
4	210237	SAFETY SIGN - OUTER GUARD	1
5	210239	SAFETY SIGN - INNER GUARD	1
6	210210	COMPLETE PTO SHAFT ASSEMBLY	1

## 4.4 Wing Deck PTO Shaft

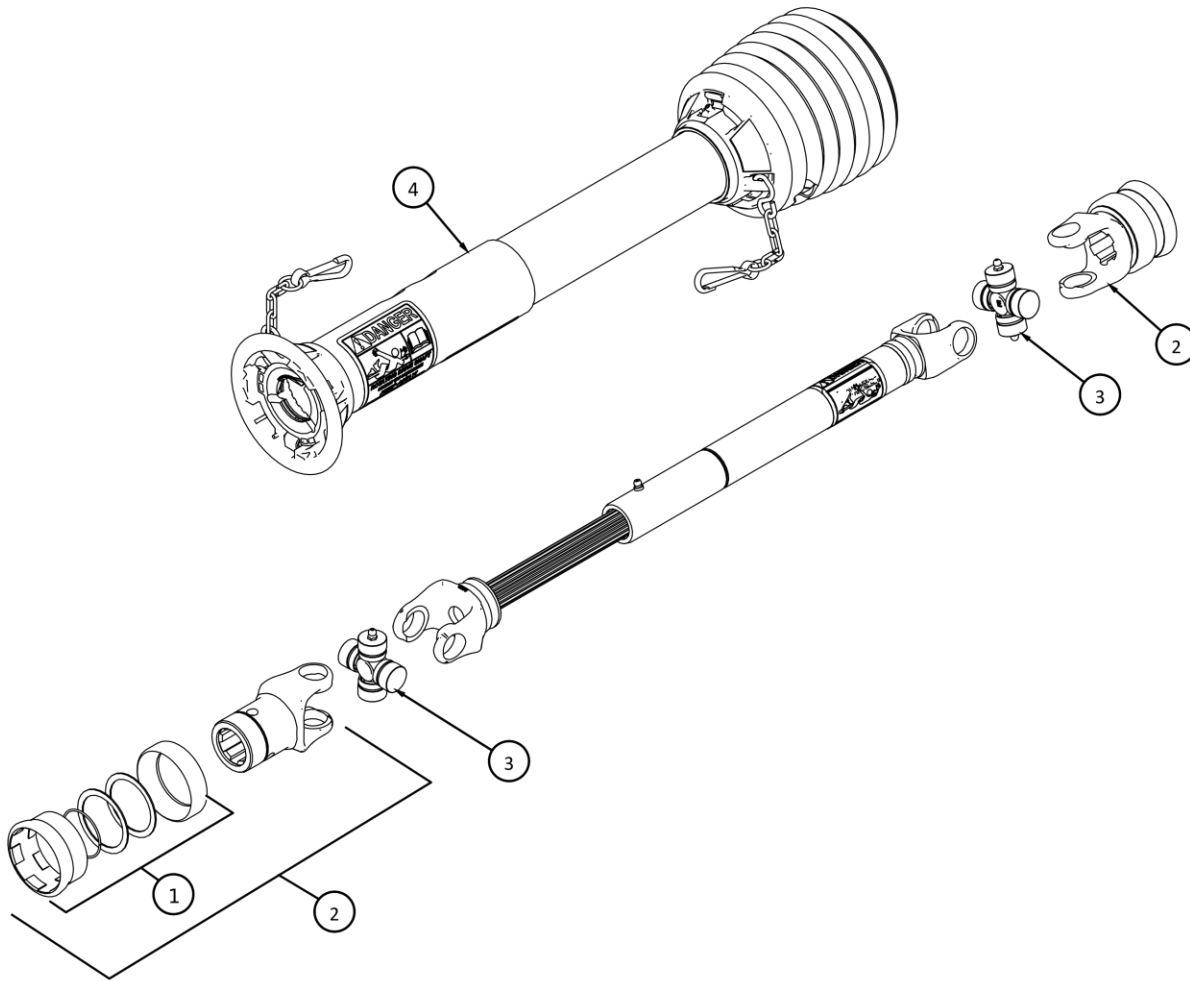

ITEM	PART #	DESCRIPTION	QTY
1	210196	REPAIR KIT, SPRING LOCK	1
2	210302	YOKE, 6 SERIES, SPRING LOCK	2
3	210303	CROSS AND BEARINGS - 6E2BL	2
4	210301	COMPLETE GUARD SET FOR 210300	1
5	210306	WING PTO SHAFT COMPLETE, 6 SERIES	1

## 4.5 Rear Deck PTO Shaft

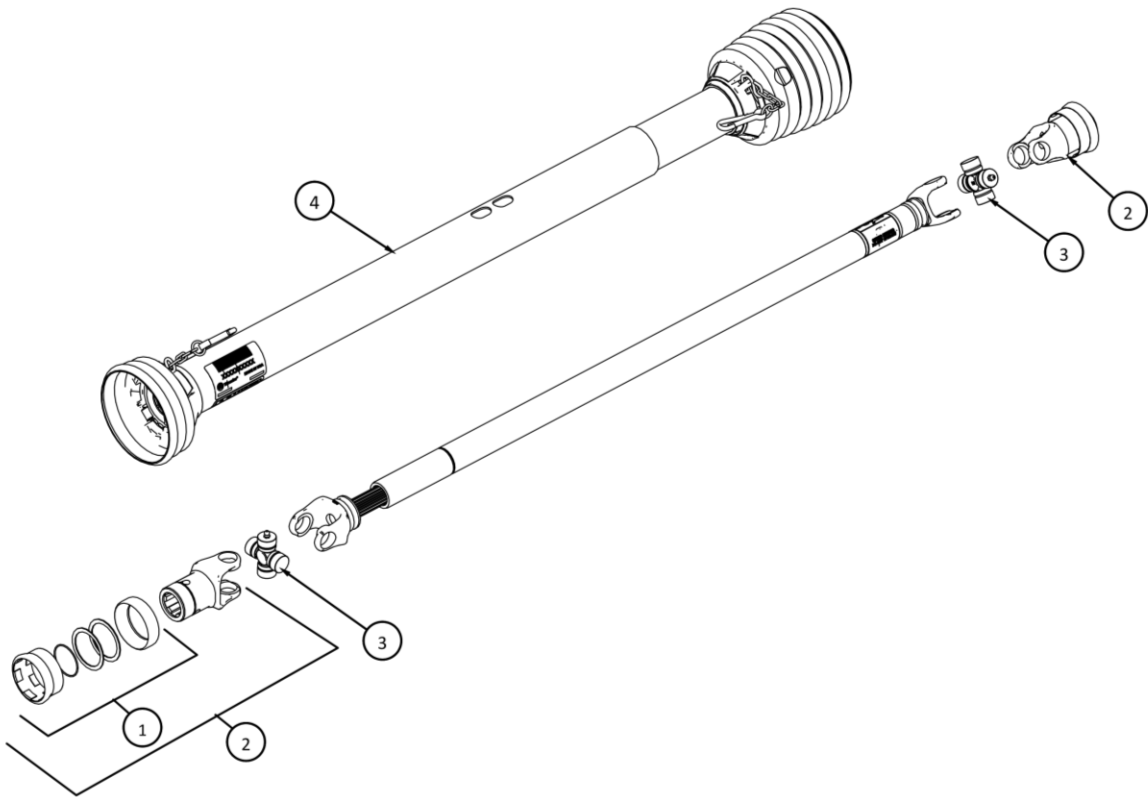

ITEM	PART #	DESCRIPTION	QTY
1	210196	REPAIR KIT, SPRING LOCK	1
2	210302	YOKE, 6 SERIES, SPRING LOCK	2
3	210303	CROSS AND BEARINGS - 6E2BL	2
4	210311	COMPLETE GUARD SET FOR 210310	1
5	210316	REAR PTO SHAFT COMPLETE, 6 SERIES	1

## 4.6 4-Way Gearbox

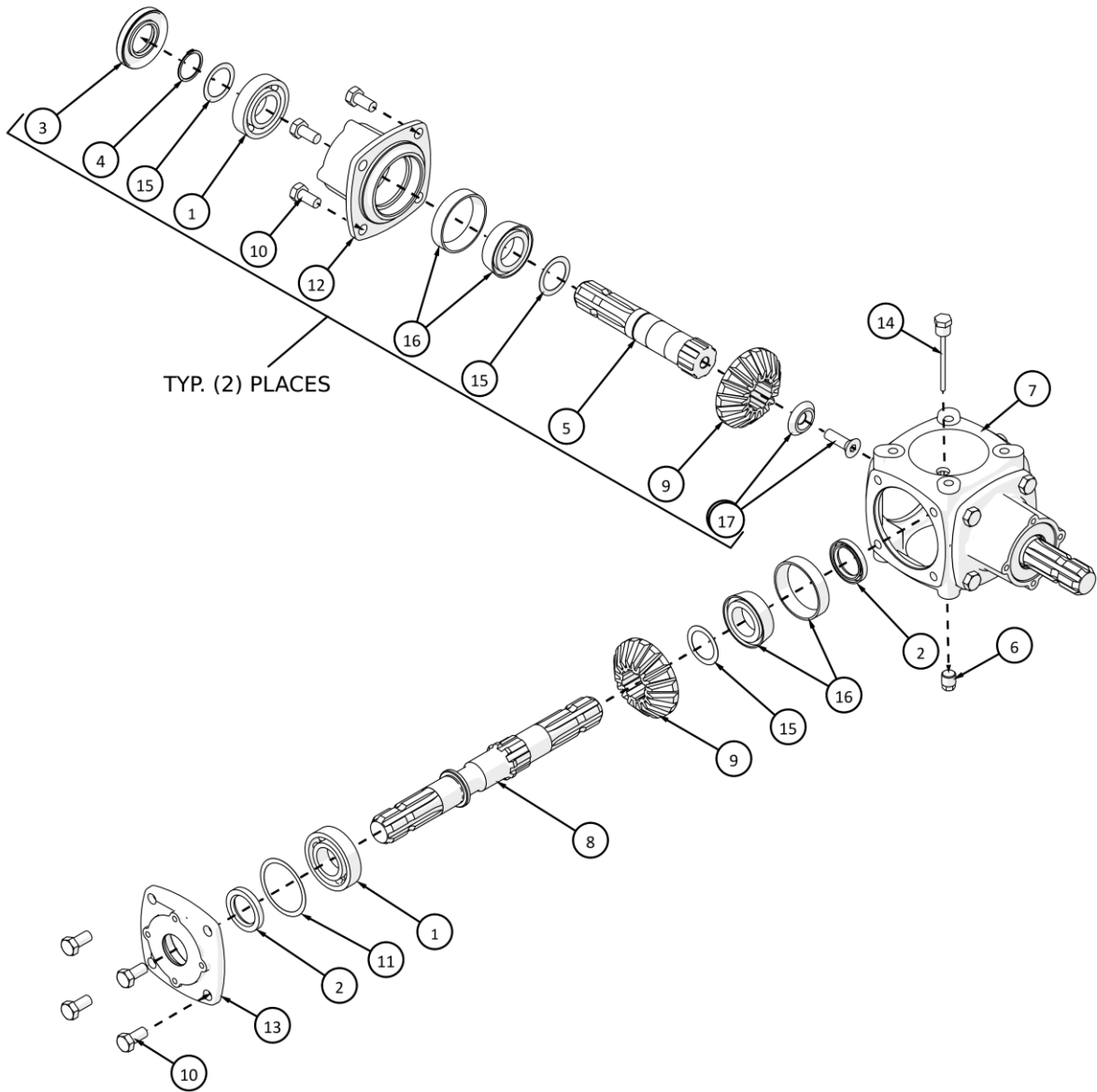

ITEM	PART #	DESCRIPTION	QTY
1	521116	BEARING - 6207	3
2	521120	OIL SEAL - 35 X 52 X 10	2
3	521127	OIL SEAL - 35 X 72 X 10	2
4	521137	SNAP RING	2
5	521481	STUB SHAFT	2
6	521482	HEX PIPE PLUG	1
7	521483	HOUSING	1
8	521486	THRU SHAFT	1
9	521487	GEAR	3
10	521488	BOLT - M12 X 25 - 8.8 (6 PCS)	12

ITEM	PART #	DESCRIPTION	QTY
11	521491	SHIM KIT	1
12	521796	EXTENSION HOUSING	2
13	521797	COVER	1
14	521489	OIL LEVEL DIPSTICK	1
15	521794	SHIM KIT	5
16	521362	BEARING - TAPERED	3
17	522426	BOLT AND WASHER KIT (4 PCS)	2
18	521497B	COMPLETE GEARBOX BLACK	1

## 4.7 Deck Gearbox

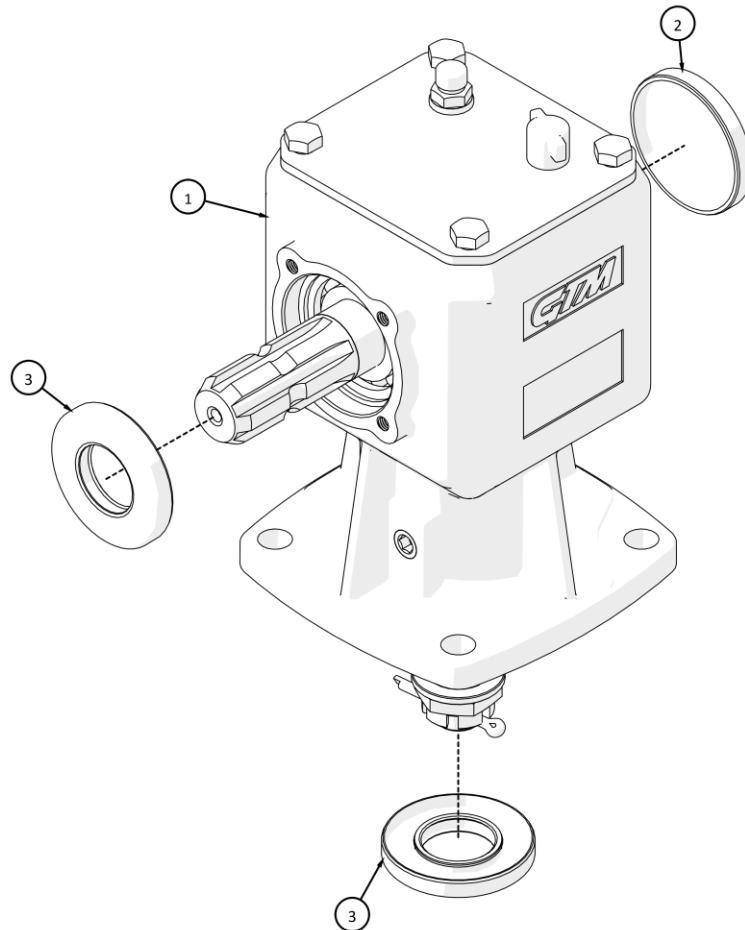

ITEM	PART #	DESCRIPTION	QTY
1	215116	GEAR BOX RG-30	1
2	521443	END CAP 72 X 10	1
3	521127	OIL SEAL 35 X 72 X 10	2

# 5 DECALS

## 5.1 Safety

If decals become faded, damaged, or lost, replace immediately. Order decal according to corresponding part number below. Complete decal kits are also available.

### 541503 - KIT - SAFETY DECALS FOR TDR-X



209175  
DECAL – GENERAL SAFETY

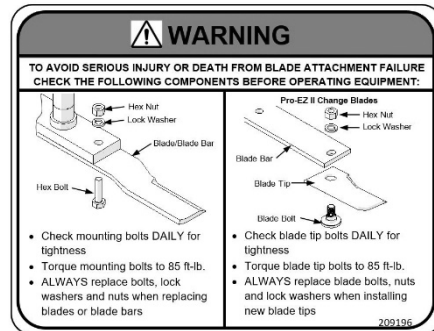

209196  
DECAL - BLADE HARDWARE



209113  
DECAL – REPLACE SHIELDS



209174  
DECAL - CAUTION



209173  
DECAL - ROTATING BLADE DANGER



209115  
DECAL – OEM PARTS



521817  
DECAL – PROGRESSIVE TURF (B Models)

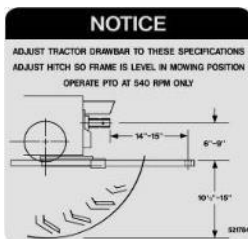

521784  
DECAL – HITCH SETUP

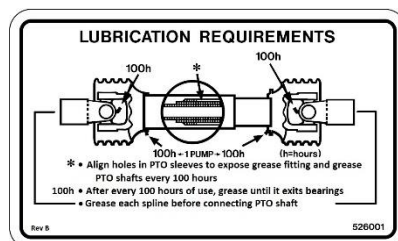

526001  
DECAL – PTO GREASE



521817DE  
DECAL – PROGRESSIVE TURF (D Models)



# TDR-X

209203  
TDR-X



210237  
SAFETY SIGN – OUTER GUARD



210238  
DECAL – CE WARNING



GREASE POINT DECAL  
(521014)

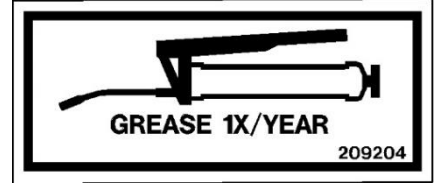

GREASE X PER YEAR  
(209204)

